



PARTS CATALOGUE

YFZ350T (5FKY) U49, OCEANIA

YFZ350T (3B51) CANADA

YFZ350T (3B52) FRANCE



1D5FK-100EA

(2D5FK-100EA)

YFZ350T
PARTS CATALOGUE
©2004 by Yamaha Motor Co., Ltd.
1st edition, July 2004
All rights reserved.
Any reprinting or unauthorized use
without the written permission of
Yamaha Motor Co., Ltd.
is expressly prohibited.
Printed in Japan.

A3



A4

FOREWORD

This Parts Catalogue is related to the parts for the model(s) on the cover page. When you are ordering replacement parts, please refer to this Parts Catalogue and quote both part numbers and part names correctly.

1. Modifications or additions which have been made after the issue of the Parts Catalogue will be announced in the Parts News.

It is advisable that you make the necessary corrections to the Parts Catalogue according to the Parts News.

2. Abbreviations

The following abbreviations are used in this Parts Catalogue.

“UR” Use specified parts number.

“UN” Use as many as needed.

“AP” Alternate Parts

“LM” Locally Made (Parts need to be ordered locally)

“F#” Frame No. (Applicable machine No.)

“O/S” Over Size

3. The number of components for assembly

- Parts, which are to be supplied in an assembly, are listed with a dot (.) in front of the part name as shown below.
- The numeral appearing to the right of each component part indicates the quantity of parts for each assembly unit.

PART NO.	DESCRIPTION	Q'TY	REMARKS
2F5-83310-60	FRONT FLASHER LIGHT ASSY	2	
115-83311-60	.BULB (6V-18W)	1	

4. Applicable colours of graphics are represented in the “REMARKS” as shown below.

PART NO.	DESCRIPTION	Q'TY	REMARKS
2N4-24110-00-X5	FUEL TANK COMP.	2	MXR
3J1-24240-10	.GRAPHIC, FUEL TANK	1	FOR MXR

5. Note that the illustrations for reference in finding parts numbers are not to be used for assembling. When assembling, please use the applicable service manual.

6. The asterisk (*) before a reference number indicates modified items after the first edition.

FOREWORD

7. Applicable Serial No.

Engine Serial No.

Frame Serial No.

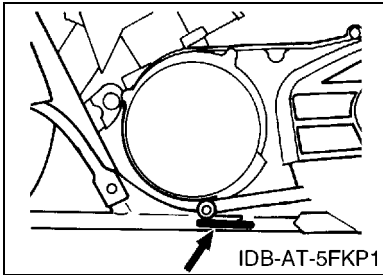
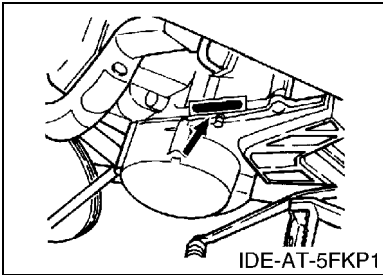

8. Applicable Colour Code (The (*) mark shows Model colour.)

Abbreviation	Colour Name	Colour Code
AMS	ALMITE SILVER	00HM
MBL2	MAT BLACK 2	0582
S8	SILVER 8	0895
SMJ(*)	BLACK METALLIC J	0906
YB	YAMAHA BLACK	0033

9. Quantity Column Information

Column No.	Name Of Q'ty Column	Destination
1	U49	U49
2	CAN	CANADA
3	FRA	FRANCE
4	OCE	AUSTRALIA, NEW ZEALAND

CONTENTS

ENGINE

CYLINDER	B2
CRANKSHAFT & PISTON	B3
WATER PUMP	B4
RADIATOR & HOSE	B5
INTAKE	B6
CARBURETOR	B8
EXHAUST	B10
CRANKCASE	B11
CRANKCASE COVER 1	B13
STARTER	B14
CLUTCH	B15
TRANSMISSION	C3
SHIFT CAM & FORK	C5
SHIFT SHAFT	C6

CHASSIS

FRAME	C7
FRONT FENDER	C9
REAR FENDER	C10
SIDE COVER	C11
REAR ARM	C12
REAR SUSPENSION	C14
STEERING	C15
FRONT SUSPENSION & WHEEL	D3
FUEL TANK	D5
SEAT	D6
FRONT WHEEL	D7
FRONT BRAKE CALIPER	D8
REAR WHEEL	D9
REAR BRAKE CALIPER	D11
STEERING HANDLE & CABLE	D12
FRONT MASTER CYLINDER	D14
STAND & FOOTREST	D15
REAR MASTER CYLINDER	E2
GUARD	E3
GENERATOR	E4
HEADLIGHT	E5
TAILLIGHT	E6
HANDLE SWITCH & LEVER	E7
ELECTRICAL 1	E9
ELECTRICAL 2	E10

EMBLEM & LABEL 1	E11
EMBLEM & LABEL 2	E12
EMBLEM & LABEL 3	E14
EMBLEM & LABEL 4	E15

INDEX

NUMERICAL INDEX	M1
-----------------------	----

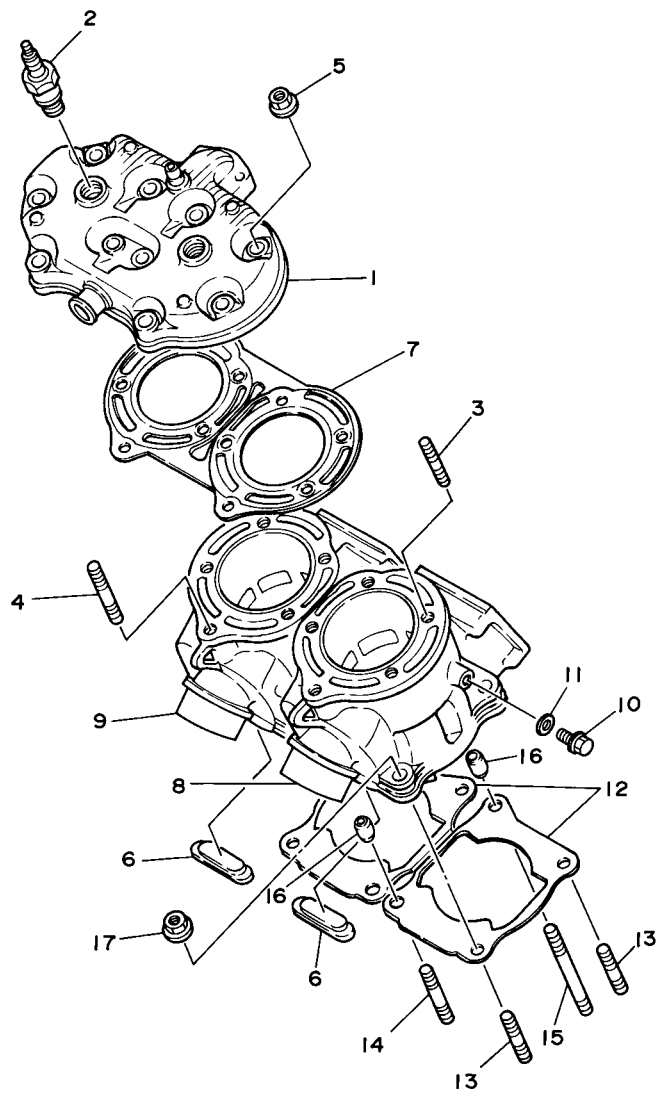

2GU110-7010

FIG. 1 CYLINDER

REF. NO.	PART NO.	DESCRIPTION	U49	CAN	FRA	OCE	REMARKS
1	2GU-11111-00	HEAD, CYLINDER 1	1	1	1	1	
2	94701-00204	PLUG, SPARK (NGK BR8ES)	2			2	
	94702-00204	PLUG, SPARK (NGK BR8ES)		2	2		
3	90116-08394	BOLT, STUD	8	8	8	8	
4	95917-08640	BOLT, STUD	2	2	2	2	
5	90179-08299	NUT	10	10	10	10	
6	47X-11355-00	SEAL, CYLINDER 1	2	2	2	2	
7	2GU-11181-00	GASKET, CYLINDER HEAD 1	1	1	1	1	
8	2GU-11311-00	CYLINDER 1	1	1	1	1	
9	2GU-11321-00	CYLINDER 2	1	1	1	1	
10	95827-06010	BOLT, FLANGE	2	2	2	2	
11	90430-06166	GASKET	2	2	2	2	
12	3GG-11351-01	GASKET, CYLINDER	2	2	2	2	
13	90116-08318	BOLT, STUD	4	4	4	4	
14	90116-08388	BOLT, STUD	2	2	2	2	
15	90116-08064	BOLT, STUD	2	2	2	2	
16	99530-10114	PIN, DOWEL	4	4	4	4	
17	90179-08299	NUT	8	8	8	8	

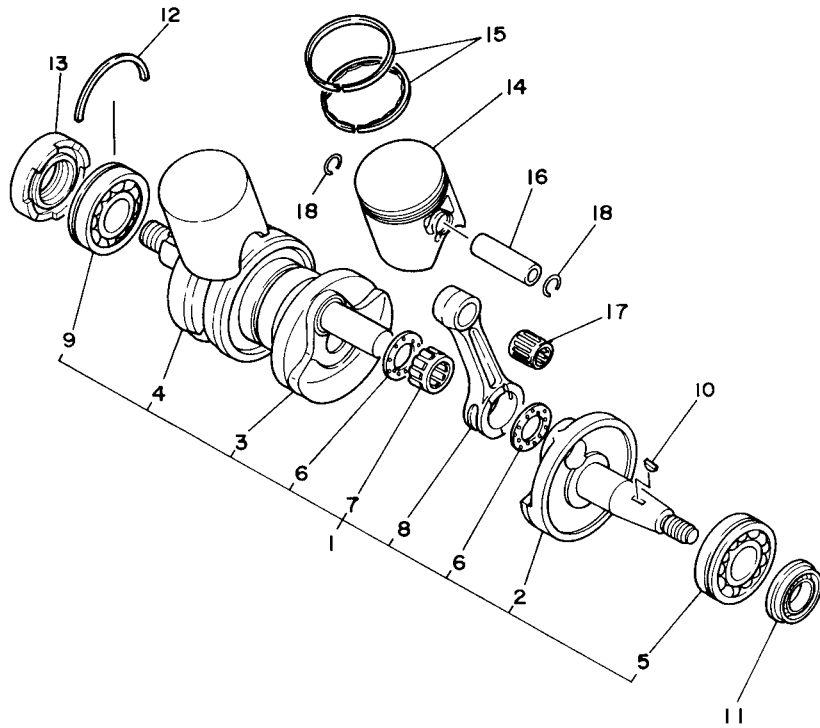

29L010-3021

FIG. 2 CRANKSHAFT & PISTON

REF. NO.	PART NO.	DESCRIPTION	U49	CAN	FRA	OCE	REMARKS
1	29L-11400-30	CRANKSHAFT ASSY	1	1	1	1	
2	29L-11412-00	.CRANK 1	1	1	1	1	
3	29L-11409-30	.CRANK SUB ASSY	1	1	1	1	
4	29L-11442-10	.CRANK 4	1	1	1	1	
5	93306-30548	.BEARING	1	1	1	1	
6	90209-22292	.WASHER	4	4	4	4	
7	93310-522L4	.BEARING	2	2	2	2	
8	29L-11651-00	.ROD, CONNECTING	2	2	2	2	
9	93306-30549	.BEARING	1	1	1	1	
10	90280-05033	KEY, WOODRUFF	1	1	1	1	
11	93103-25108	OIL SEAL	1	1	1	1	
12	278-17424-01	CIRCLIP 1	1	1	1	1	
13	93103-40077	OIL SEAL	1	1	1	1	
14	2GU-11631-00-94	PISTON (STD)	2	2	2	2	
	2GU-11635-00	PISTON (0.25MM O/S)	2	2	2	2	AP
	2GU-11636-00	PISTON (0.50MM O/S)	2	2	2	2	AP
15	2GU-11610-01	PISTON RING SET (STD)	2	2	2	2	
	2GU-11610-11	PISTON RING SET (0.25MM O/S)	2	2	2	2	AP
	2GU-11610-21	PISTON RING SET (0.50MM O/S)	2	2	2	2	AP
16	4L0-11633-00	PIN, PISTON	2	2	2	2	
17	93310-316H6	BEARING	2	2	2	2	
18	93450-17129	CIRCLIP	4	4	4	4	

FIG. 3 WATER PUMP

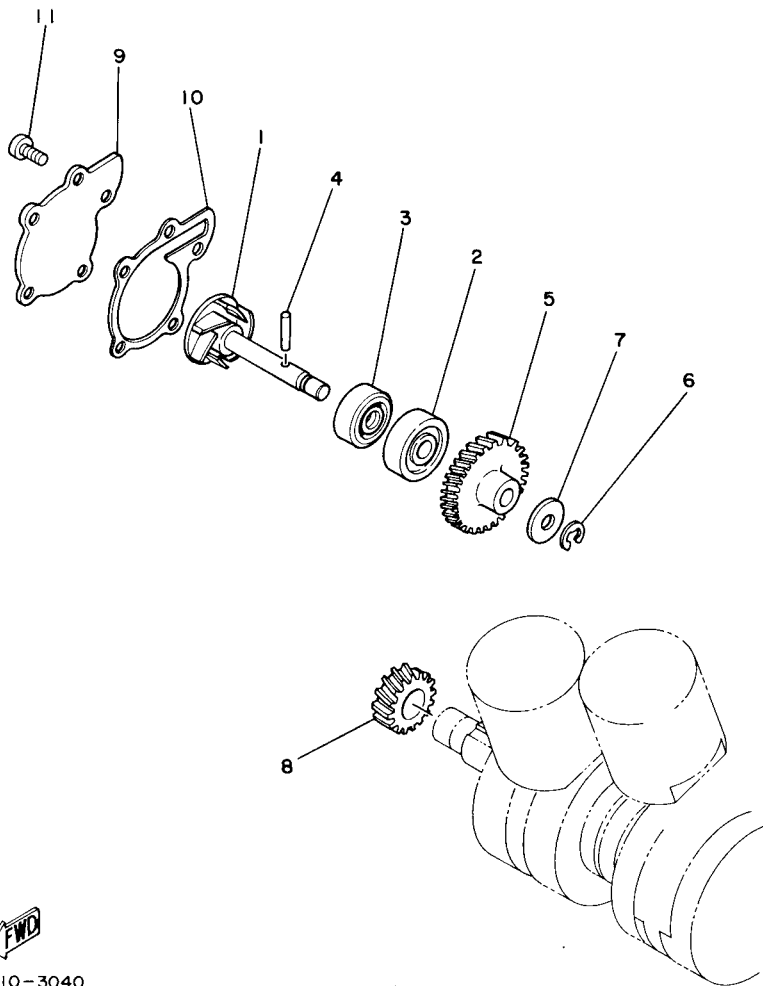

29L010-3040

REF. NO.	PART NO.	DESCRIPTION	U49	CAN	FRA	OCE	REMARKS
1	4L0-12450-01	IMPELLER SHAFT ASSY	1	1	1	1	
2	93306-30002	BEARING	1	1	1	1	
3	93103-10147	OIL SEAL	1	1	1	1	
4	93603-22028	PIN, DOWEL	1	1	1	1	
5	4L0-12459-00	GEAR, IMPELLER SHAFT	1	1	1	1	
6	99001-07600	CIRCLIP	1	1	1	1	
7	90201-08784	WASHER, PLATE	1	1	1	1	
8	4L0-12436-00	GEAR, DRIVE	1	1	1	1	
9	4L0-12422-00	COVER, HOUSING	1	1	1	1	
10	3GG-12428-01	GASKET, HOUSING COVER 2	1	1	1	1	
11	98507-06016	SCREW, PAN HEAD	5	5	5	5	

FIG. 4 RADIATOR & HOSE

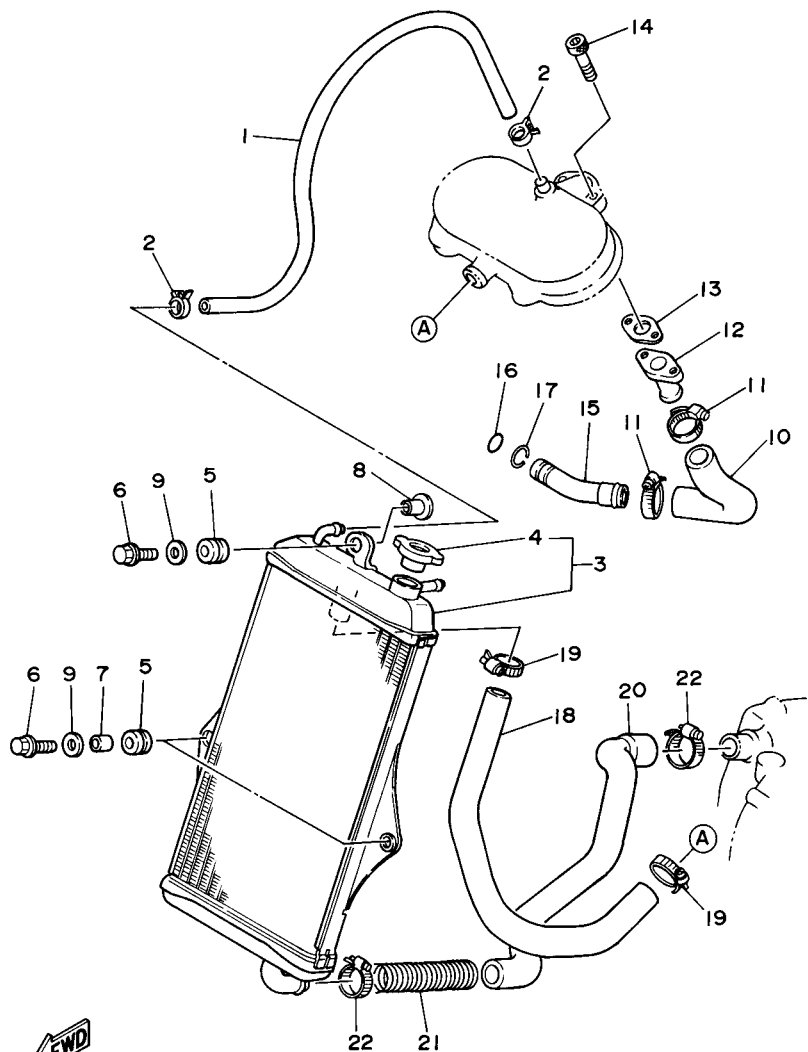

2GU110-7040

REF. NO.	PART NO.	DESCRIPTION	U49	CAN	FRA	OCE	REMARKS
1	2GU-12485-00	PIPE 5	1	1	1	1	
2	90467-13083	CLIP	2	2	2	2	
3	2GU-12460-01	RADIATOR ASSY	1	1	1	1	
4	22W-12462-00	.CAP, RADIATOR	1	1	1	1	
5	90480-15470	GROMMET	3	3	3	3	
6	95807-06025	BOLT, FLANGE	3	3	3	3	
7	90387-0714B	COLLAR	2	2	2	2	
8	90387-063G3	COLLAR	1	1	1	1	
9	90201-060A3	WASHER, PLATE	3	3	3	3	
10	29L-12481-00	PIPE 1	1	1	1	1	
11	90450-32015	HOSE CLAMP ASSY	2	2	2	2	
12	4L0-12479-00	JOINT	1	1	1	1	
13	3XV-12435-00	GASKET	1	1	1	1	
14	91317-06020	BOLT	2	2	2	2	
15	29L-12469-00	JOINT 1	1	1	1	1	
16	93210-17239	O-RING	1	1	1	1	
17	93440-19083	CIRCLIP	1	1	1	1	
18	2GU-12482-00	PIPE 2	1	1	1	1	
19	90450-32015	HOSE CLAMP ASSY	2	2	2	2	
20	2GU-12484-00	PIPE 4	1	1	1	1	
21	11H-12516-00	COVER, WATER INLET	1	1	1	1	
22	90450-32015	HOSE CLAMP ASSY	2	2	2	2	

FIG. 5 INTAKE

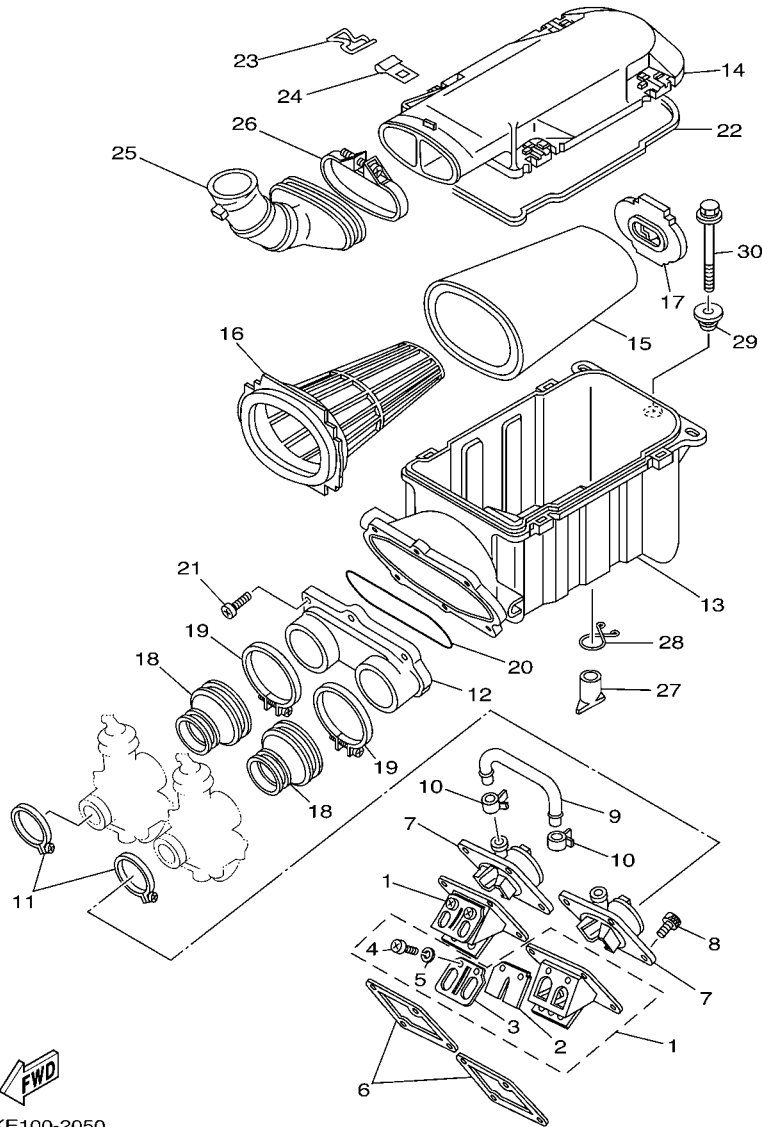

5FKE100-2050

REF. NO.	PART NO.	DESCRIPTION	U49	CAN	FRA	OCE	REMARKS
1	2GU-13610-01	REED VALVE ASSY	2	2	2	2	
2	2GU-13613-00	.REED, VALVE	2	2	2	2	
3	2GU-13616-00	.STOPPER, REED VALVE	2	2	2	2	
4	98507-03008	.SCREW, PAN HEAD	4	4	4	4	
5	92907-03100	.WASHER, SPRING	4	4	4	4	
6	3GG-13621-00	GASKET, VALVE SEAT	2	2	2	2	
7	31K-13565-01	JOINT, CARBURETOR	2	2	2	2	
8	91317-06025	BOLT	8	8	8	8	
9	29L-14465-00	PIPE	1	1	1	1	
10	90467-20085	CLIP	2	2	2	2	
11	90450-44046	HOSE CLAMP ASSY	2	2	2	2	
12	2GU-14411-00	CASE, AIR CLEANER 1	1	1	1	1	
13	2GU-14421-01	CASE, AIR CLEANER 2	1	1	1	1	
14	2GU-14412-00	CAP, CLEANER CASE 1	1	1	1	1	
15	2GU-14451-00	ELEMENT, AIR CLEANER	1	1	1	1	
16	5FK-14458-00	GUIDE	1	1	1	1	
17	2GU-14468-00	PLATE,ELEMENT FITTING	1	1	1	1	
18	29L-14453-01	JOINT, AIR CLEANER 1	2	2	2	2	
19	90460-68230	CLAMP, HOSE	2	2	2	2	
20	12R-14452-00	SEAL	1	1	1	1	
21	97707-50525	SCREW, TAPPING	6	6	6	6	
22	29L-14452-00	SEAL	1	1	1	1	
23	90465-18312	CLAMP	4	4	4	4	
24	90468-05184	CLIP	4	4	4	4	
25	2GU-14437-00	DUCT	1	1	1	1	
26	90460-99291	CLAMP, HOSE	1	1	1	1	
27	59V-14457-00	SEAL	1	1	1	1	



5FKE100-2050

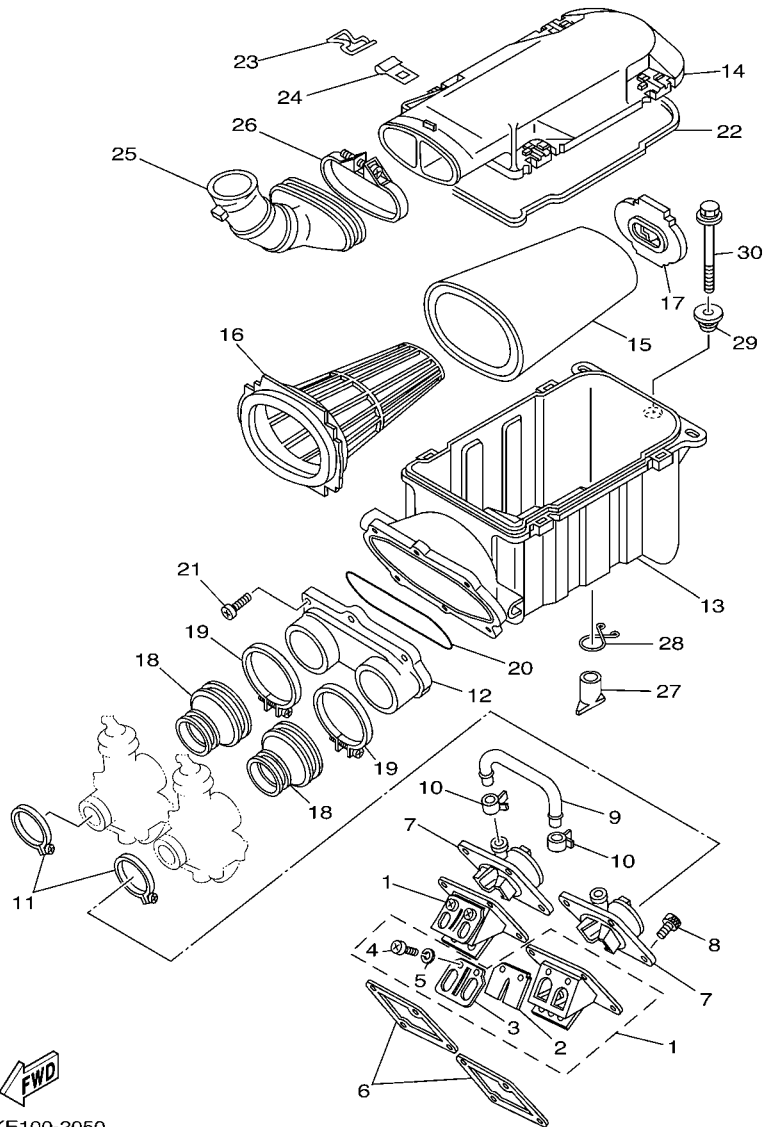
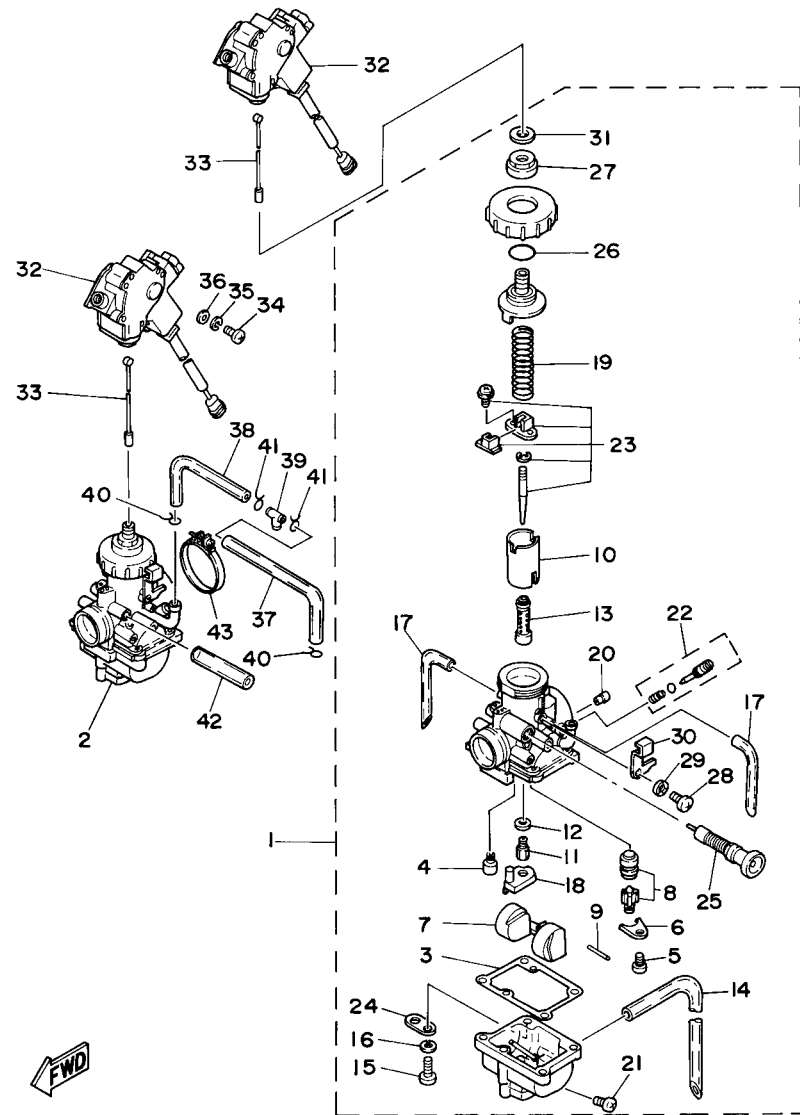

FIG. 5 INTAKE

REF. NO.	PART NO.	DESCRIPTION	U49	CAN	FRA	OCE	REMARKS
28	90467-22080	CLIP	1	1	1	1	
29	90480-18171	GROMMET	2	2	2	2	
30	90119-06096	BOLT, WITH WASHER	2	2	2	2	

FIG. 6 CARBURETOR



2GU110-7060

REF. NO.	PART NO.	DESCRIPTION	U49	CAN	FRA	OCE	REMARKS
1	2GU-14101-01	CARBURETOR ASSY 1	1	1	1	1	
2	2GU-14102-01	CARBURETOR ASSY 2	1	1	1	1	
3	304-14184-00	.GASKET, FLOAT CHAMBER	1	1	1	1	
4	260-14142-25	.JET, PILOT (# 25)	1	1	1	1	
5	98502-04008	.SCREW, PAN HEAD	1	1	1	1	
6	2H0-14146-00	.PLATE	1	1	1	1	
7	4L0-14185-00	.FLOAT	1	1	1	1	
8	1UA-14190-28	.NEEDLE VALVE ASSY	1	1	1	1	
9	537-14186-00	.PIN, FLOAT	1	1	1	1	
10	2GU-14113-20	.VALVE, THROTTLE 2	1	1	1	1	UR FOR RH
	2GU-14112-20	.VALVE, THROTTLE 1	1	1	1	1	UR FOR LH
11	137-14143-40	.JET, MAIN (#200)	1	1	1	1	UR
	137-14143-44	.JET, MAIN (#220)	1	1	1	1	UR
	137-14143-48	.JET, MAIN (#240)	1	1	1	1	UR
	137-14143-38	.JET, MAIN (#190)	1	1	1	1	UR
12	137-14153-00	.WASHER, MAIN JET	1	1	1	1	
13	4L0-14141-38	.NOZZLE, MAIN	1	1	1	1	
14	2GU-14196-00	.PIPE	1	1	1	1	
15	98511-04016	.SCREW, PAN HEAD	4	4	4	4	
16	92990-04100	.WASHER, SPRING	4	4	4	4	
17	4L0-14197-00	.PIPE	2	2	2	2	
18	2GU-14153-00	.RING	1	1	1	1	
19	2GU-14131-00	.SPRING, THROTTLE VALVE	1	1	1	1	
20	239-14172-16	.PILOT JET, AIR (1.6)	1	1	1	1	
21	12R-14191-00	.PLUG, DRAIN	1	1	1	1	
22	10W-14104-00	.AIR SCREW SET	1	1	1	1	
23	2GU-1490J-00	.NEEDLE SET	1	1	1	1	

FIG. 6 CARBURETOR

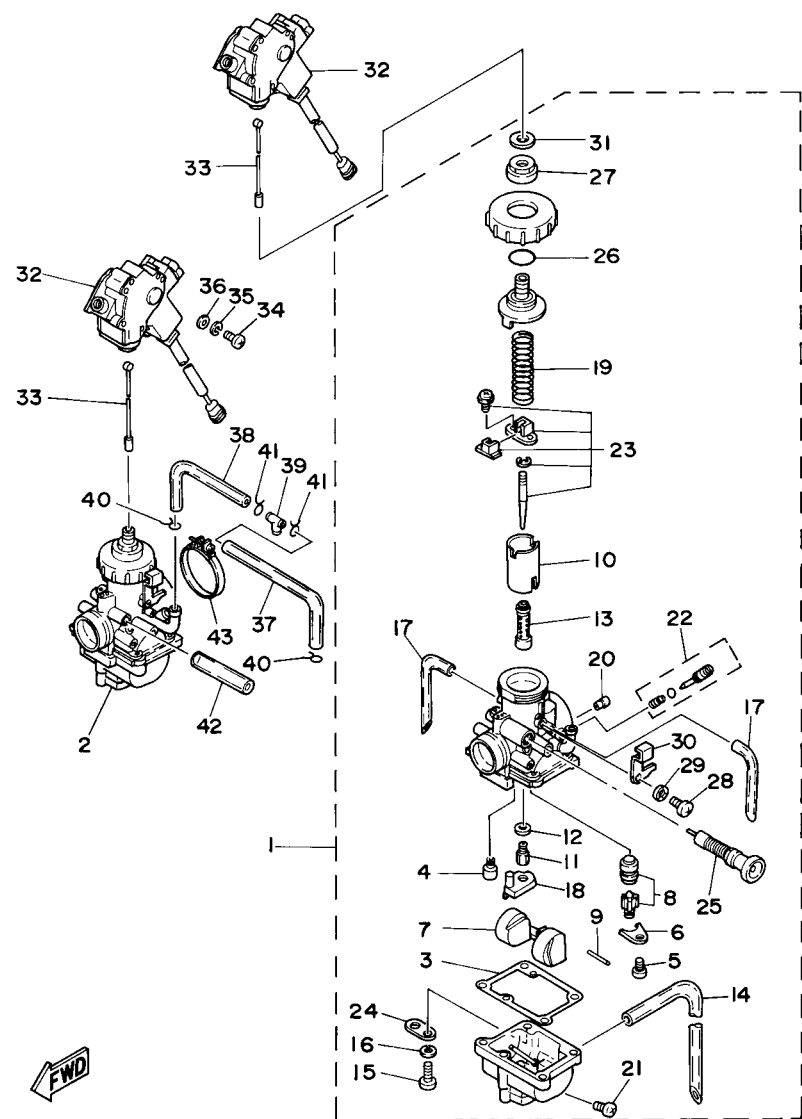

2GU110-7060

REF. NO.	PART NO.	DESCRIPTION	U49	CAN	FRA	OCE	REMARKS
24	500-14146-00	.PLATE	1	1	1	1	
25	2GU-14171-00	.PLUNGER, STARTER	1	1	1	1	LH
26	558-14147-00	.O-RING	1	1	1	1	
27	2GU-14161-00	.NUT, CABLE ADJUSTING	1	1	1	1	
28	98501-05008	.SCREW, PAN HEAD	1	1	1	1	
29	92901-05100	.WASHER, SPRING	1	1	1	1	
30	2GU-14146-00	.PLATE	1	1	1	1	UR FOR RH
	2GU-14243-00	.PLATE	1	1	1	1	UR FOR LH
31	2GU-14952-00	.WASHER	1	1	1	1	
32	3GG-8259E-00	SWITCH ASSY	2	2	2	2	
33	2GU-2633K-00	WIRE, INNER 1	2	2	2	2	
34	98507-03010	SCREW, PAN HEAD	6	6	6	6	
35	92907-03100	WASHER, SPRING	6	6	6	6	
36	92907-03600	WASHER	6	6	6	6	
37	4X7-24311-00	PIPE, FUEL 1	1	1	1	1	
38	48H-24311-00	PIPE, FUEL 1	1	1	1	1	
39	90413-08009	WAY 3	1	1	1	1	
40	90467-10008	CLIP	2	2	2	2	
41	90467-11106	CLIP	2	2	2	2	
42	90445-09012	HOSE (L70)	1	1	1	1	
43	90460-49058	CLAMP, HOSE	2	2	2	2	

FIG. 7 EXHAUST

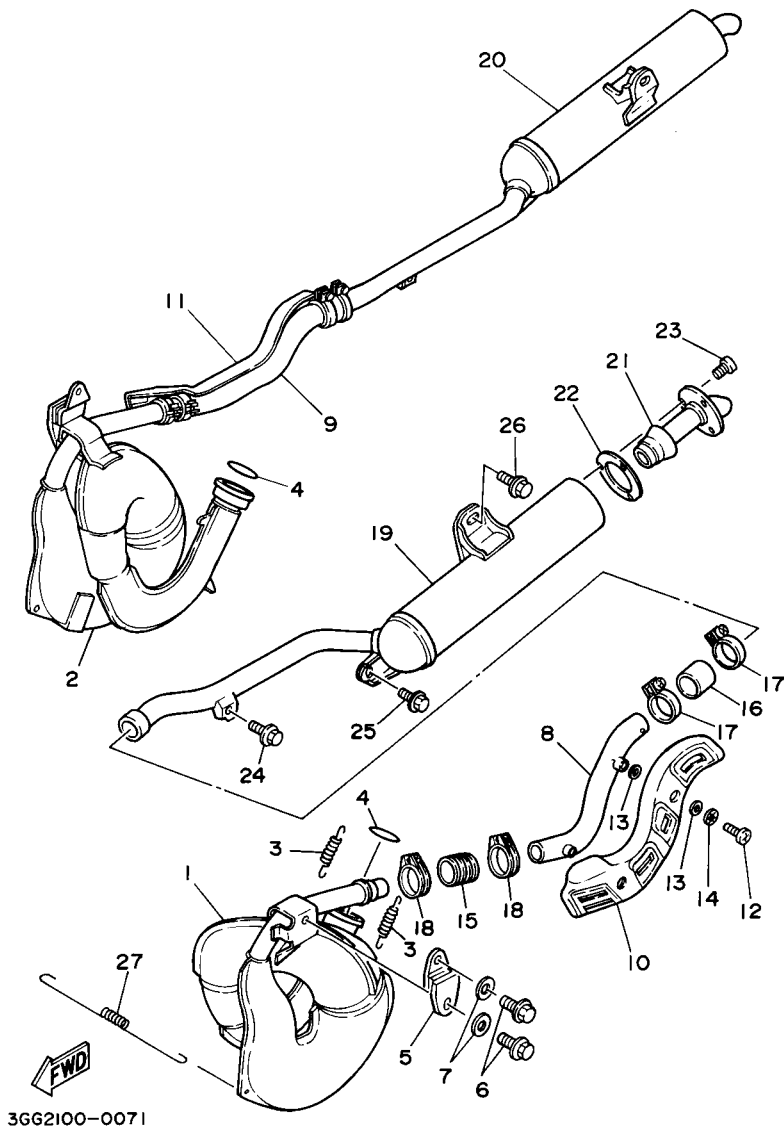

REF. NO.	PART NO.	DESCRIPTION	U49	CAN	FRA	OCE	REMARKS
1	2GU-14610-00	EXHAUST PIPE ASSY 1	1	1	1	1	
2	2GU-14620-00	EXHAUST PIPE ASSY 2	1	1	1	1	
3	90507-20030	SPRING, TENSION	4	4	4	4	
4	93210-45742	O-RING	2	2	2	2	
5	2GU-14771-00	STAY, MUFFLER 1	2	2	2	2	
6	95817-08014	BOLT, FLANGE	4	4	4	4	
7	90201-08326	WASHER, PLATE	4	4	4	4	
8	2GU-14635-00	JOINT, EXHAUST 3	1	1	1	1	
9	2GU-14645-00	JOINT, EXHAUST 4	1	1	1	1	
10	2GU-14718-00	PROTECTOR, MUFFLER 1	1	1	1	1	
11	2GU-14728-00	PROTECTOR, MUFFLER 2	1	1	1	1	
12	98907-06010	SCREW, BIND	4	4	4	4	
13	4BD-14766-00	WASHER, PROTECTOR	8	8	8	8	
14	90206-06090	WASHER, WAVE	4	4	4	4	
15	1W2-14714-00	GASKET, MUFFLER	2	2	2	2	
16	2GU-14615-00	JOINT, EXHAUST 1	2	2	2	2	
17	90460-37026	CLAMP, HOSE	4	4	4	4	
18	90460-37026	CLAMP, HOSE	4	4	4	4	
19	2GU-14753-01	SILENCER, EXHAUST	1	1	1	1	
20	2GU-14765-01	SILENCER	1	1	1	1	
21	2GU-14752-00	PIPE, OUTLET	2	2	2	2	
22	2GU-14613-10	GASKET, EXHAUST PIPE	2	2	2	2	
23	98907-06010	SCREW, BIND	6	6	6	6	
24	95817-08014	BOLT, FLANGE	2	2	2	2	
25	95817-08014	BOLT, FLANGE	2	2	2	2	
26	95817-08014	BOLT, FLANGE	2	2	2	2	
27	90506-18398	SPRING, TENSION	1	1	1	1	

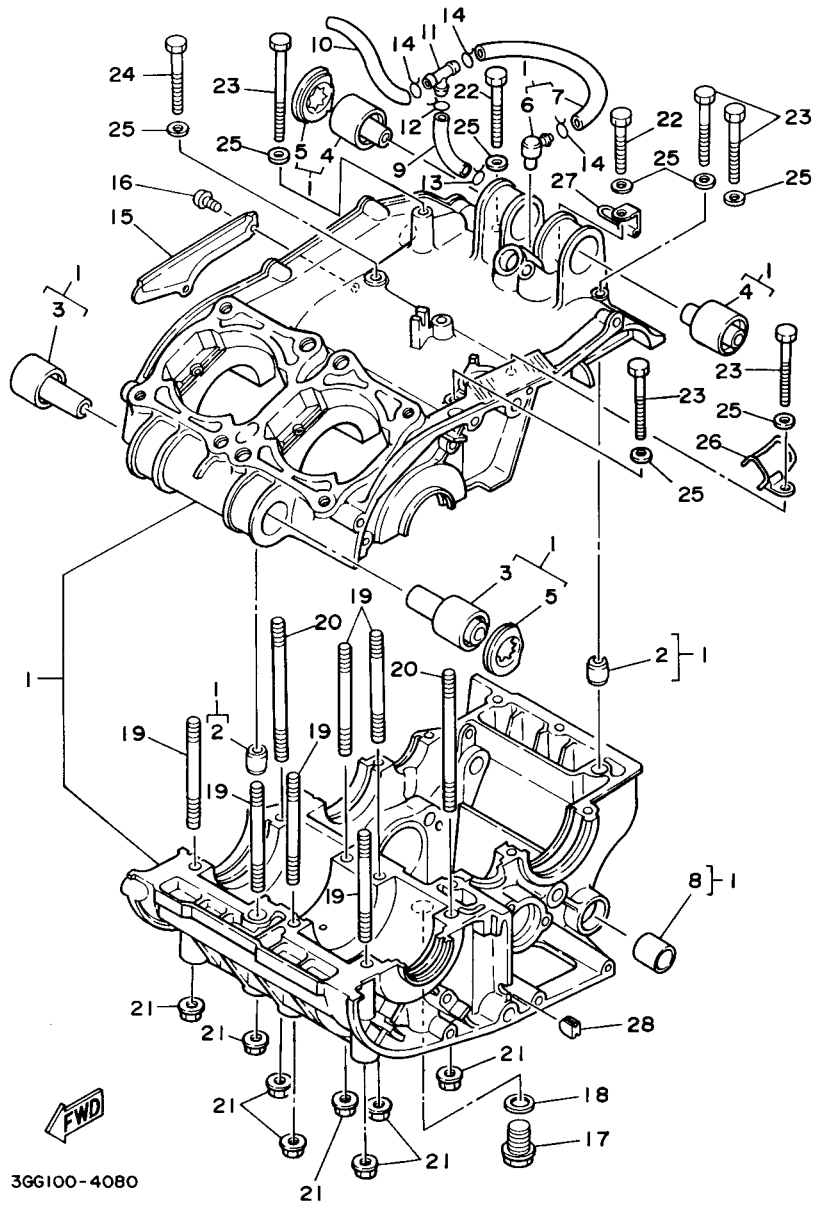

366100-4080

FIG. 8 CRANKCASE

REF. NO.	PART NO.	DESCRIPTION	U49	CAN	FRA	OC	REMARKS
1	2GU-15100-01	CRANKCASE ASSY	1	1	1	1	
2	99510-12016	.PIN, DOWEL	2	2	2	2	
3	2GU-15316-00	.DAMPER, ENGINE MOUNT 1	2	2	2	2	
4	2GU-15326-00	.DAMPER, ENGINE MOUNT 2	2	2	2	2	
5	2GU-15328-00	.SPACER, DAMPER	2	2	2	2	
6	120-15371-00	.BREATHER	1	1	1	1	
7	90445-09109	.HOSE (L400)	1	1	1	1	
8	90383-12022	.BUSH, FORMED	1	1	1	1	
9	90445-081F1	HOSE (L508)	1	1	1	1	
10	90445-09123	HOSE (L730)	1	1	1	1	
11	90413-05014	WAY 3	1	1	1	1	
12	90467-08021	CLIP	1	1	1	1	
13	90467-07093	CLIP	1	1	1	1	
14	90467-08075	CLIP	3	3	3	3	
15	278-15492-01	COVER	1	1	1	1	
16	98507-05010	SCREW, PAN HEAD	2	2	2	2	
17	90340-14132	PLUG, STRAIGHT SCREW	1	1	1	1	
18	90430-14043	GASKET	1	1	1	1	
19	90116-08064	BOLT, STUD	6	6	6	6	
20	90116-08232	BOLT, STUD	2	2	2	2	
21	95707-08500	NUT, FLANGE	8	8	8	8	
22	97017-06045	BOLT	2	2	2	2	
23	97017-06060	BOLT	5	5	5	5	
24	97017-06090	BOLT	1	1	1	1	
25	92907-06200	WASHER	8	8	8	8	
26	90462-16130	CLAMP	1	1	1	1	
27	90465-06094	CLAMP	1	1	1	1	

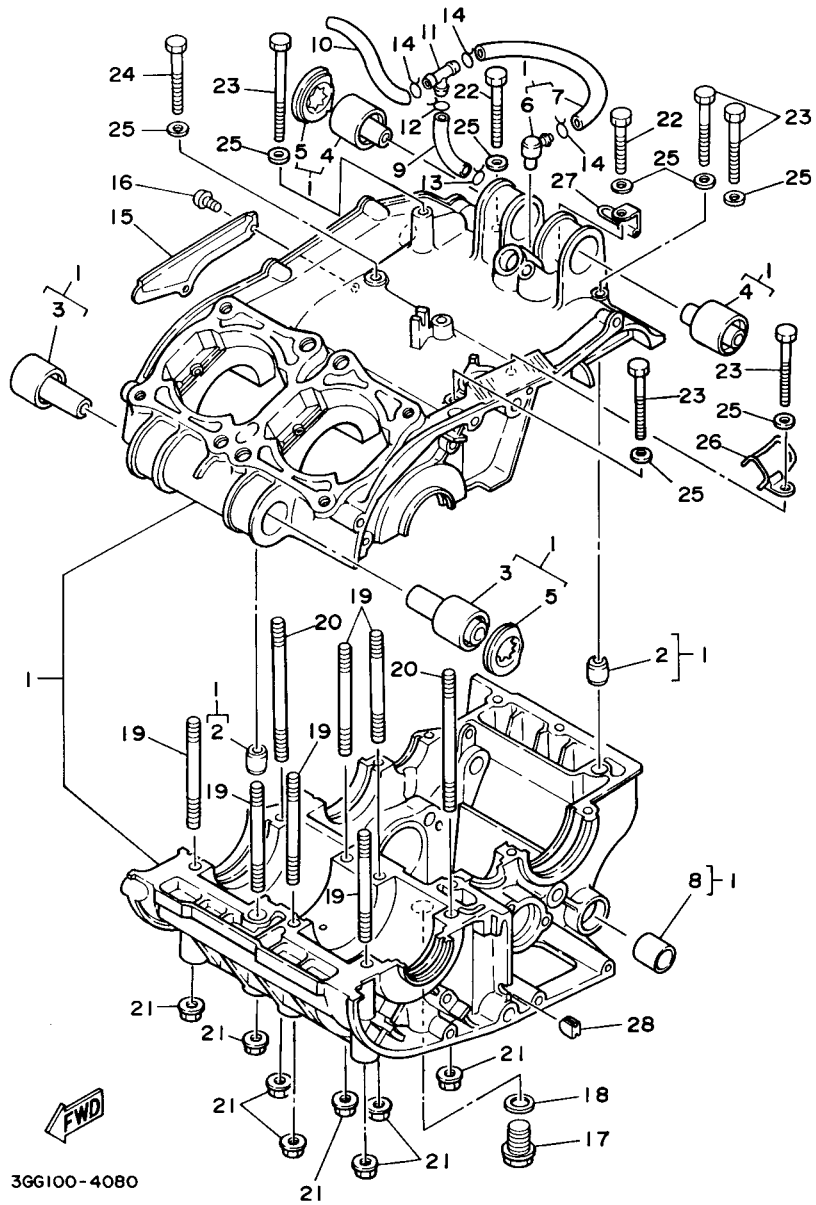
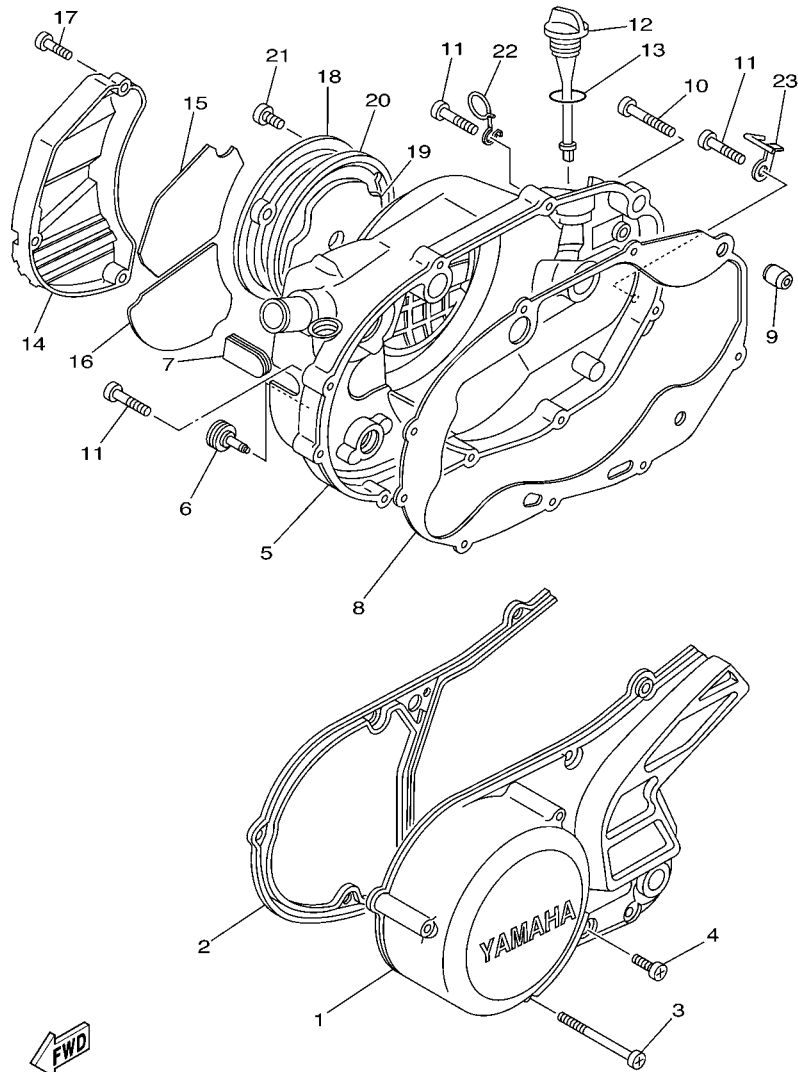

FIG. 8 CRANKCASE

REF. NO.	PART NO.	DESCRIPTION	U49	CAN	FRA	OCE	REMARKS
28	90338-06190	PLUG	1	1	1	1	



FWD
5FKE100-2090

FIG. 9 CRANKCASE COVER 1

REF. NO.	PART NO.	DESCRIPTION	U49	CAN	FRA	OCE	REMARKS
1	2GU-15411-00	COVER, CRANKCASE 1	1	1	1	1	
2	2GU-15379-00	SEAL, CRANKCASE	1	1	1	1	
3	98507-06055	SCREW, PAN HEAD	3	3	3	3	
4	98507-06020	SCREW, PAN HEAD	4	4	4	4	
5	2GU-15421-00	COVER, CRANKCASE 2	1	1	1	1	
6	2GU-15189-00	PLUG	1	1	1	1	
7	90338-15189	PLUG	1	1	1	1	
8	3GG-15461-02	GASKET, CRANKCASE COVER 2	1	1	1	1	
9	99530-12016	PIN, DOWEL	1	1	1	1	
10	98507-06040	SCREW, PAN HEAD	1	1	1	1	
11	98507-06030	SCREW, PAN HEAD	8	8	8	8	
12	4L0-15362-00	PLUG, OIL LEVEL	1	1	1	1	
13	93210-19123	O-RING	1	1	1	1	
14	2GU-15416-00	COVER, OIL PUMP	1	1	1	1	
15	2GU-15337-00	DAMPER 4	1	1	1	1	
16	2GU-15338-00	DAMPER, ENGINE MOUNT 5	1	1	1	1	
17	98507-06020	SCREW, PAN HEAD	3	3	3	3	
18	4L0-15431-01	COVER, CRANKCASE 3	1	1	1	1	
19	31K-15317-00	SPACER, ENGINE MOUNT	1	1	1	1	
20	48H-15327-00	SPACER, ENGINE MOUNT	1	1	1	1	
21	98507-05014	SCREW, PAN HEAD	3	3	3	3	
22	90465-32317	CLAMP	1	1	1	1	
23	5FK-15377-00	GUIDE, INLET	1	1	1	1	

FIG. 10 STARTER

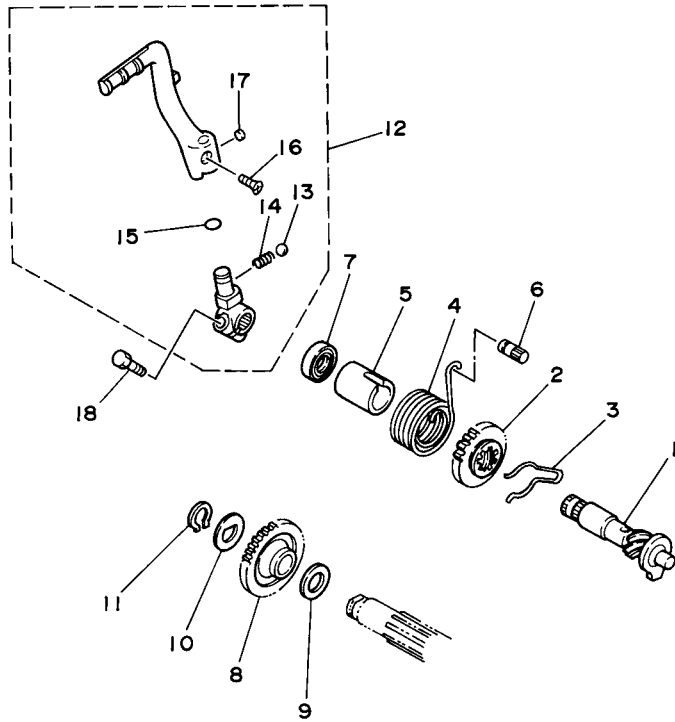

2GU110-7100

REF. NO.	PART NO.	DESCRIPTION	U49	CAN	FRA	OCE	REMARKS
1	4L0-15660-01	KICK AXLE ASSY	1	1	1	1	
2	4L0-15641-00	GEAR, KICK (22T)	1	1	1	1	
3	90468-26091	CLIP	1	1	1	1	
4	90508-30051	SPRING, TORSION	1	1	1	1	
5	4L0-15666-00	SPACER	1	1	1	1	
6	248-15668-00	STOPPER	1	1	1	1	
7	93102-20484	OIL SEAL	1	1	1	1	
8	4L0-15651-00	GEAR, KICK IDLE (26T)	1	1	1	1	
9	164-17417-00-10	SHIM 1 (1.0T)	1	1	1	1	
10	90214-15020	WASHER, CLAW	1	1	1	1	
11	99009-15400	CIRCLIP	1	1	1	1	
12	2GU-15620-01	KICK CRANK ASSY	1	1	1	1	
13	93507-32031	.BALL	1	1	1	1	
14	90501-12081	.SPRING, COMPRESSION	1	1	1	1	
15	93210-14369	.O-RING	1	1	1	1	
16	90152-06010	.SCREW, COUNTERSUNK	1	1	1	1	
17	90336-42049	.PLUG, TAPER	1	1	1	1	
18	97027-08030	BOLT	1	1	1	1	

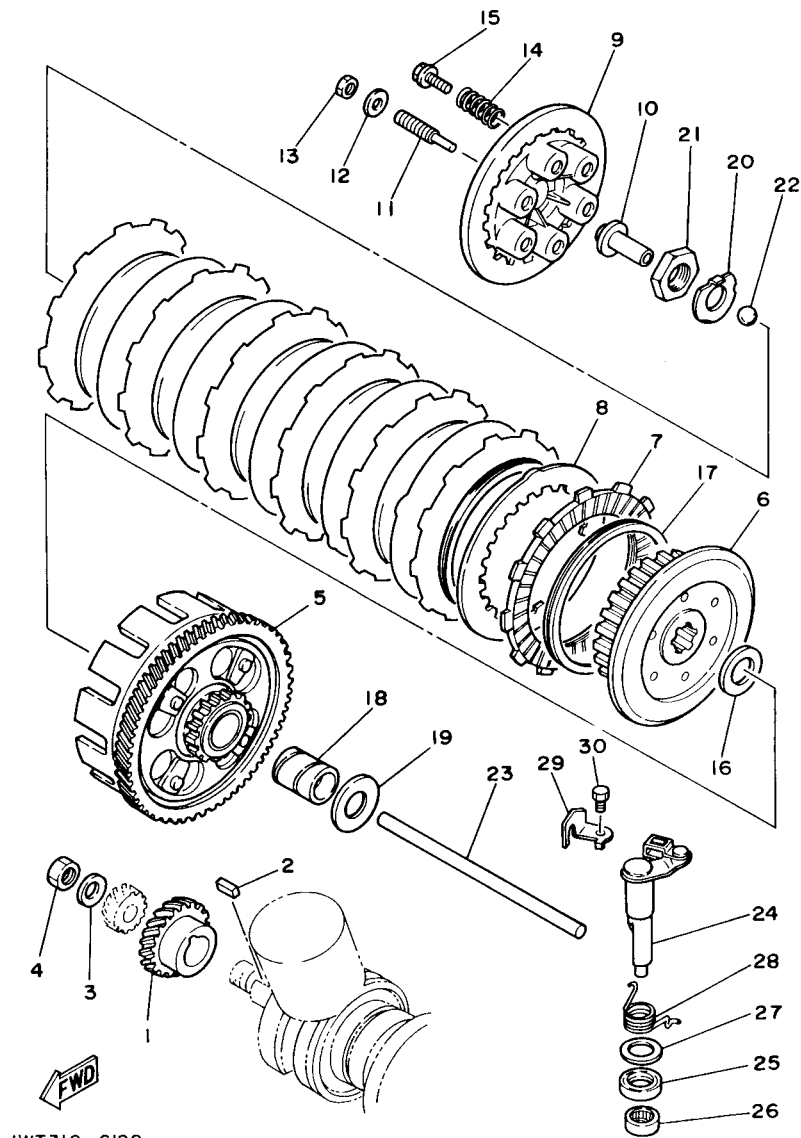

IWT 310 - 6120

FIG. 11 CLUTCH

REF. NO.	PART NO.	DESCRIPTION	U49	CAN	FRA	OCE	REMARKS
1	4L0-16111-00	GEAR, PRIMARY DRIVE (23T)	1	1	1	1	
2	90282-07023	KEY, STRAIGHT	1	1	1	1	
3	90208-16019	WASHER, CONICAL SPRING	1	1	1	1	
4	90170-16425	NUT	1	1	1	1	
5	31K-16150-10	PRIMARY DRIVEN GEAR COMP.	1	1	1	1	
6	1A0-16371-00	BOSS, CLUTCH	1	1	1	1	
7	5Y1-16331-01	PLATE, FRICTION 2	7	7	7	7	
8	498-16325-00	PLATE, CLUTCH 2	6	6	6	6	
9	29L-16351-00	PLATE, PRESSURE 1	1	1	1	1	
10	29L-16356-00	ROD, PUSH 1	1	1	1	1	
11	90149-08143	SCREW	1	1	1	1	
12	92907-08200	WASHER	1	1	1	1	
13	95317-08700	NUT	1	1	1	1	
14	90501-23138	SPRING, COMPRESSION	6	6	6	6	
15	90159-06016	SCREW, WITH WASHER	6	6	6	6	
16	360-16154-00	PLATE, THRUST 1	1	1	1	1	
17	278-16367-00	RING, CUSHION	7	7	7	7	
18	278-16181-01	SPACER 1	1	1	1	1	
19	360-16154-00	PLATE, THRUST 1	1	1	1	1	
20	90215-20223	WASHER, LOCK	1	1	1	1	
21	90170-20320	NUT	1	1	1	1	
22	93515-32029	BALL	1	1	1	1	
23	29L-16357-00	ROD, PUSH 2	1	1	1	1	
24	29L-16380-00	PUSH LEVER ASSY	1	1	1	1	
25	93102-17004	OIL SEAL	1	1	1	1	
26	93315-11720	BEARING	1	1	1	1	
27	90201-17327	WASHER, PLATE	1	1	1	1	

FIG. 12 TRANSMISSION

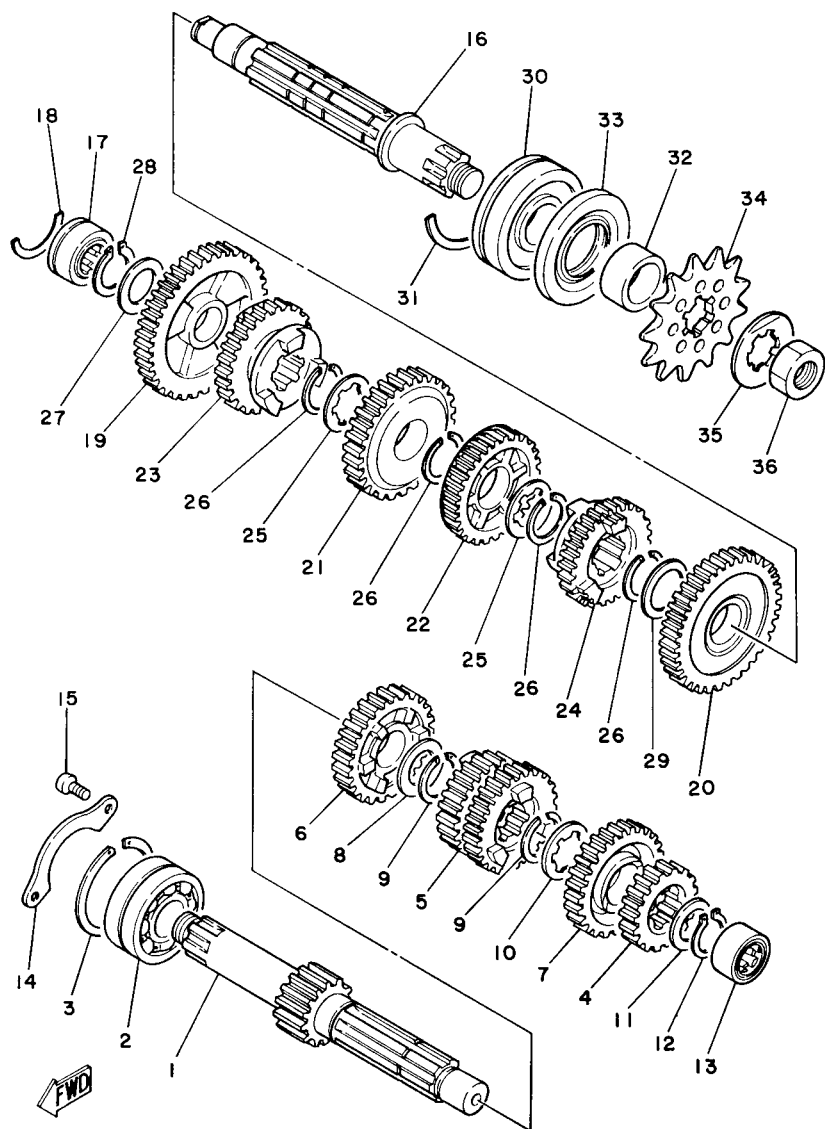

2GU110-7120

REF. NO.	PART NO.	DESCRIPTION	U49	CAN	FRA	OCE	REMARKS
1	2GU-17411-00	AXLE, MAIN	1	1	1	1	
2	93305-20508	BEARING	1	1	1	1	
3	93440-52009	CIRCLIP	1	1	1	1	
4	2GU-17121-00	GEAR, 2ND PINION (16T)	1	1	1	1	
5	2GU-17131-00	GEAR, 3RD/4TH PINION (18T/20T)	1	1	1	1	
6	2GU-17151-00	GEAR, 5TH PINION (22T)	1	1	1	1	
7	2GU-17161-00	GEAR, 6TH PINION (24T)	1	1	1	1	
8	90201-256E6	WASHER, PLATE (T=0.9)	1	1	1	1	
9	93440-25084	CIRCLIP	2	2	2	2	
10	90209-21105	WASHER	1	1	1	1	
11	90201-20266	WASHER, PLATE (T=1.0)	1	1	1	1	
12	99009-20400	CIRCLIP	1	1	1	1	
13	93311-22005	BEARING	1	1	1	1	
14	4L0-17471-00	PLATE, COVER	1	1	1	1	
15	98507-06012	SCREW, PAN HEAD	2	2	2	2	
16	29L-17421-00	AXLE, DRIVE	1	1	1	1	
17	93311-42006	BEARING	1	1	1	1	
18	278-17425-00	CIRCLIP 2	1	1	1	1	
19	2GU-17211-00	GEAR, 1ST WHEEL (32T)	1	1	1	1	
20	2GU-17221-00	GEAR, 2ND WHEEL (29T)	1	1	1	1	
21	2GU-17231-00	GEAR, 3RD WHEEL (27T)	1	1	1	1	
22	2GU-17241-00	GEAR, 4TH WHEEL (25T)	1	1	1	1	
23	2GU-17251-00	GEAR, 5TH WHEEL (23T)	1	1	1	1	
24	2GU-17261-01	GEAR, 6TH WHEEL (21T)	1	1	1	1	
25	90209-21105	WASHER	2	2	2	2	
26	93440-25084	CIRCLIP	4	4	4	4	
27	90201-20276	WASHER, PLATE (T=1.0)	1	1	1	1	

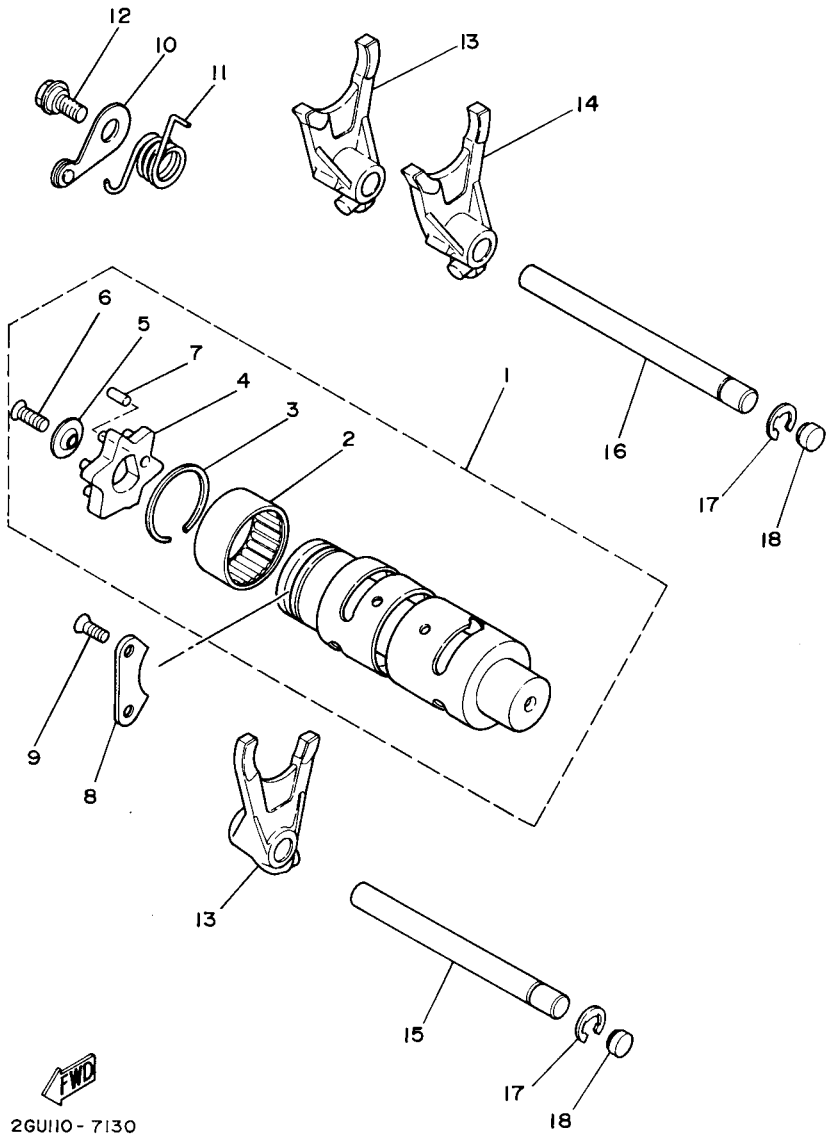

26U110 - 7130

FIG. 13 SHIFT CAM & FORK

REF. NO.	PART NO.	DESCRIPTION	U49	CAN	FRA	OCE	REMARKS
1	2GU-18540-00	SHIFT CAM ASSY	1	1	1	1	
2	93315-23612	.BEARING	1	1	1	1	
3	93440-34025	.CIRCLIP	1	1	1	1	
4	4L0-18185-00	.SEGMENT	1	1	1	1	
5	3R4-18561-00	.PLATE, SIDE 1	1	1	1	1	
6	98707-05016	.SCREW, FLAT HEAD	1	1	1	1	
7	93604-12037	.PIN, DOWEL	1	1	1	1	
8	4L0-18562-00	PLATE, STOPPER 2	1	1	1	1	
9	98707-06014	SCREW, FLAT HEAD	2	2	2	2	
10	4L0-18140-00	STOPPER LEVER ASSY	1	1	1	1	
11	90508-29728	SPRING, TORSION	1	1	1	1	
12	90109-063F7	BOLT	1	1	1	1	
13	2GU-18511-00	FORK, SHIFT 1	2	2	2	2	
14	2GU-18512-00	FORK, SHIFT 2	1	1	1	1	
15	4L0-18531-01	BAR, SHIFT FORK GUIDE 1	1	1	1	1	
16	29L-18535-00	BAR, SHIFT FORK GUIDE 2	1	1	1	1	
17	93430-08007	CIRCLIP	2	2	2	2	
18	90334-10006	PLUG, STRAIGHT	2	2	2	2	

FIG. 15 FRAME

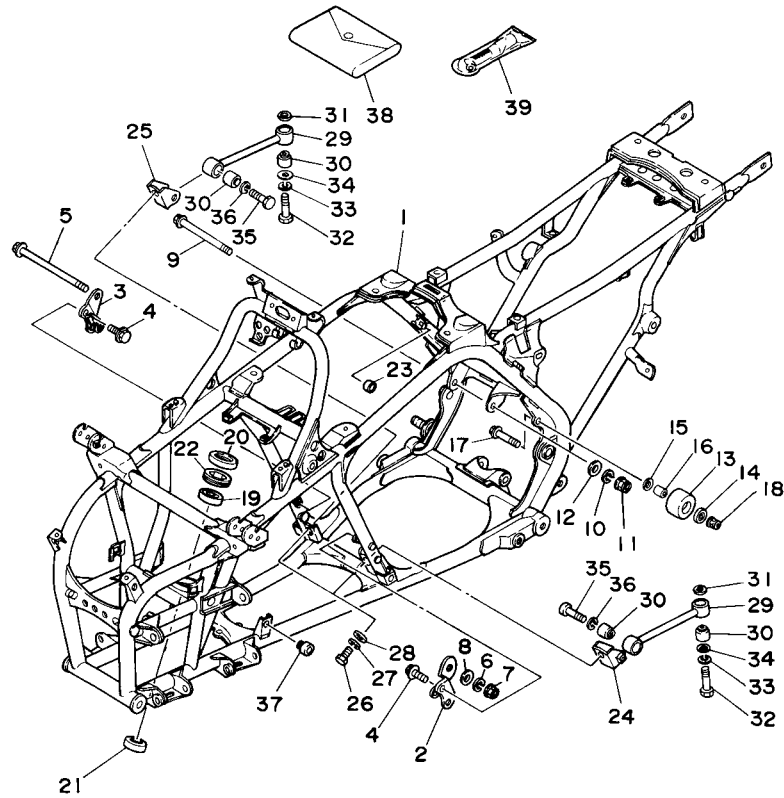

3GG4100-1150

REF. NO.	PART NO.	DESCRIPTION	U49	CAN	FRA	OCE	REMARKS
1	3GG-21110-21-P0	FRAME COMP.	1	1	1	1	MBL2
2	2GU-21315-00	STAY, ENGINE 2	1	1	1	1	
3	2GU-21316-00	STAY, ENGINE 3	1	1	1	1	
4	95817-08025	BOLT, FLANGE	4	4	4	4	
5	90105-10444	BOLT, FLANGE	1	1	1	1	
6	92907-10100	WASHER, SPRING	1	1	1	1	
7	95317-10600	NUT	1	1	1	1	
8	92990-10600	WASHER, PLATE	1	1	1	1	
9	90105-10328	BOLT, FLANGE	1	1	1	1	
10	92907-10100	WASHER, SPRING	1	1	1	1	
11	95317-10600	NUT	1	1	1	1	
12	92990-10600	WASHER, PLATE	1	1	1	1	
13	2HH-22178-00	TENSIONER	2	2	2	2	
14	93300-60804	BEARING	2	2	2	2	
15	90201-086P8	WASHER, PLATE	2	2	2	2	
16	90387-086N4	COLLAR	2	2	2	2	
17	95027-08045	BOLT, FLANGE	2	2	2	2	
18	95607-08200	NUT, SELF-LOCKING	2	2	2	2	
19	93306-20331	BEARING	1	1	1	1	
20	93102-25081	OIL SEAL	1	1	1	1	
21	93102-25099	OIL SEAL	1	1	1	1	
22	2GU-23872-00	HOLDER, BEARING	1	1	1	1	
23	90480-12299	GROMMET	2	2	2	2	
24	2GU-21317-00	STAY, ENGINE 3	1	1	1	1	
25	2GU-21318-00	STAY, ENGINE 4	1	1	1	1	
26	97027-10020	BOLT	2	2	2	2	
27	92907-10100	WASHER, SPRING	2	2	2	2	

FIG. 15 FRAME

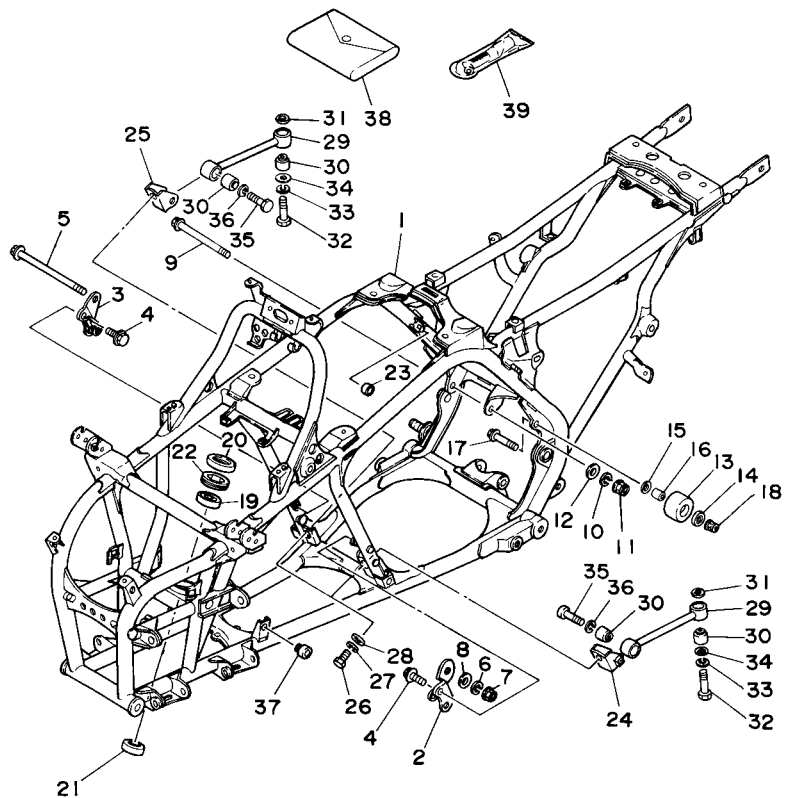

FWD
3664100-1150

REF. NO.	PART NO.	DESCRIPTION	U49	CAN	FRA	OCE	REMARKS
28	92907-10600	WASHER, PLATE	2	2	2	2	
29	2GU-21314-00	STAY, ENGINE 5	2	2	2	2	
30	4L0-21485-00	DAMPER, RUBBER 1	4	4	4	4	
31	92907-10600	WASHER, PLATE	2	2	2	2	
32	97027-10045	BOLT	2	2	2	2	
33	92907-10100	WASHER, SPRING	2	2	2	2	
34	92907-10600	WASHER, PLATE	2	2	2	2	
35	97027-10040	BOLT	2	2	2	2	
36	92907-10100	WASHER, SPRING	2	2	2	2	
37	4N0-27114-00	STOPPER, MAIN STAND	2	2	2	2	
38	2GU-28100-10	TOOL KIT	1	1	1	1	
39	1NV-2811A-01	GAUGE, AIR	1	1	1	1	

FIG. 16 FRONT FENDER

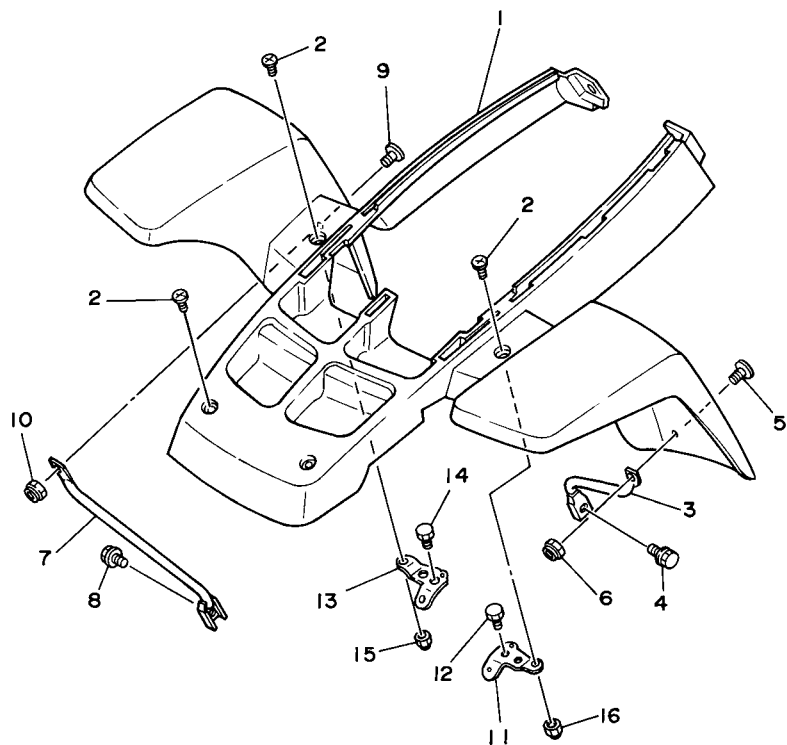

REF. NO.	PART NO.	DESCRIPTION	U49	CAN	FRA	OCE	REMARKS
1	2GU-W2151-F0	FRONT FENDER COMP.	1				
	2GU-W215C-F0	FRONT FENDER COMP.2		1			
	2GU-W215B-F0	FRONT FENDER COMP. 2			1		
	2GU-W215E-F0	FRONT FENDER COMP.				1	
2	90149-06306	SCREW	4	4	4	4	
3	2GU-21513-00	STAY, FENDER 1	1	1	1	1	
4	95827-06010	BOLT, FLANGE	1	1	1	1	
5	90149-06306	SCREW	1	1	1	1	
6	95607-06100	NUT, U	1	1	1	1	
7	2GU-21514-00	STAY, FENDER 2	1	1	1	1	
8	95827-06010	BOLT, FLANGE	1	1	1	1	
9	90149-06306	SCREW	1	1	1	1	
10	95607-06100	NUT, U	1	1	1	1	
11	2GU-21587-00	STAY 1	1	1	1	1	
12	97027-08016	BOLT	1	1	1	1	
13	2GU-21588-00	STAY 2	1	1	1	1	
14	97027-08016	BOLT	1	1	1	1	
15	95607-06100	NUT, U	1	1	1	1	
16	95607-06100	NUT, U	1	1	1	1	



3GG100-9160

FIG. 17 REAR FENDER

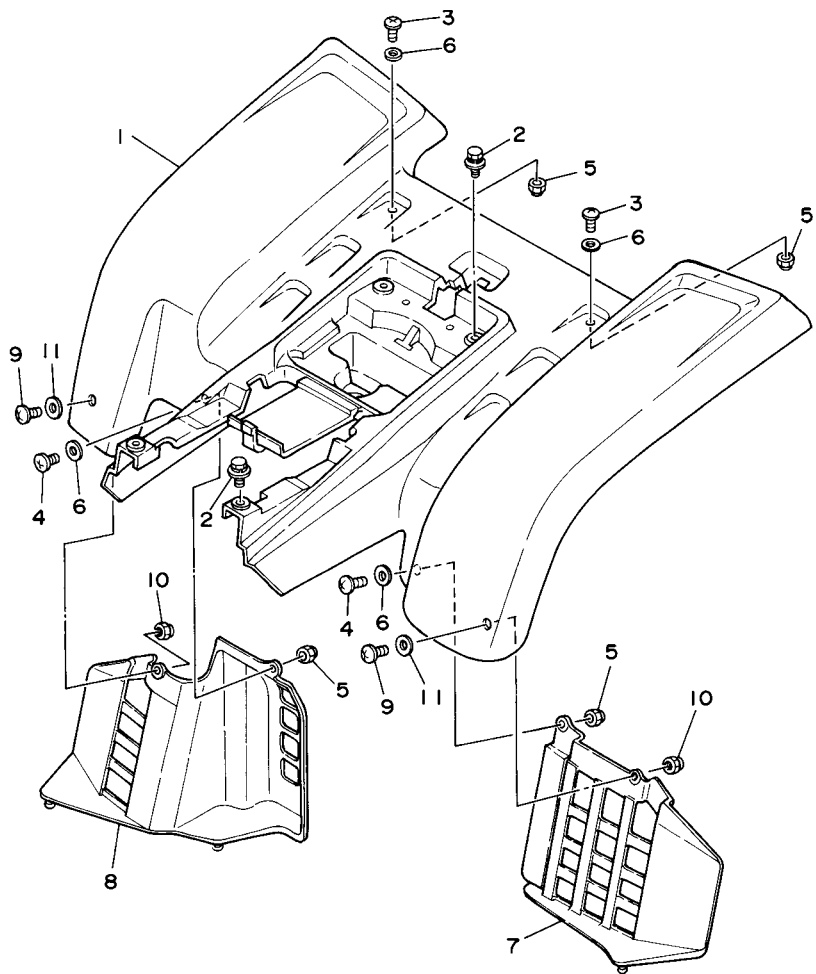

FWD
3GG2100-0170

REF. NO.	PART NO.	DESCRIPTION	U49	CAN	FRA	OCE	REMARKS
1	2GU-W2161-E0	REAR FENDER COMP.	1			1	
	2GU-W216C-E0	REAR FENDER COMP.2		1			
	2GU-W216B-E0	REAR FENDER COMP.2			1		
2	90119-06056	BOLT, WITH WASHER	4	4	4	4	
3	90149-06306	SCREW	2	2	2	2	
4	90150-06037	SCREW, ROUND HEAD	2	2	2	2	
5	95607-06100	NUT, U	4	4	4	4	
6	92907-06200	WASHER	4	4	4	4	
7	3GG-21691-00	FLAP	1	1	1	1	YB
8	3GG-21621-00	FLAP	1	1	1	1	YB
9	90149-06306	SCREW	2	2	2	2	
10	95607-06100	NUT, U	2	2	2	2	
11	92907-06200	WASHER	2	2	2	2	

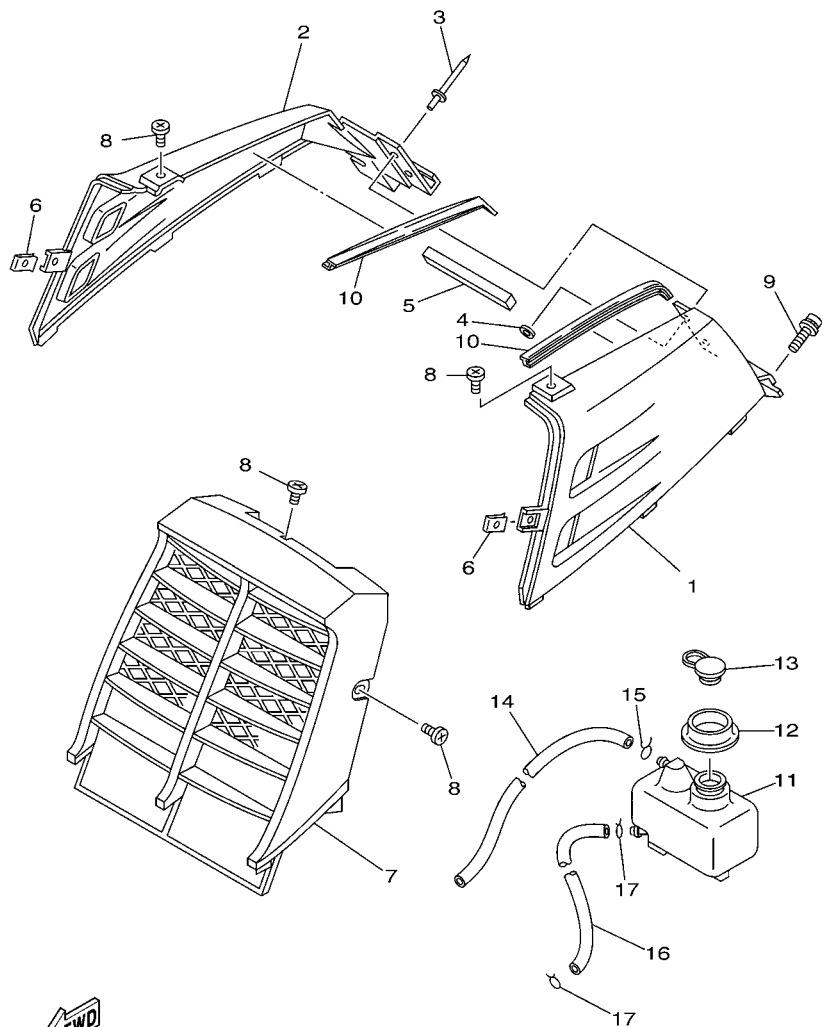

5FK6100-0180

FIG. 18 SIDE COVER

REF. NO.	PART NO.	DESCRIPTION	U49	CAN	FRA	OCE	REMARKS
1	2GU-21711-B0	COVER, SIDE 1	1	1	1	1	
2	2GU-21721-B0	COVER, SIDE 2	1	1	1	1	
3	90267-40076	RIVET, BLIND	2	2	2	2	
4	90201-047A2	WASHER, PLATE	2	2	2	2	
5	2GU-21747-00	DAMPER	1	1	1	1	
6	90183-05024	NUT, SPRING	2	2	2	2	
7	5FK-23391-D0	PANEL, FRONT	1	1	1	1	
8	90154-05013	SCREW, BINDING	5	5	5	5	
9	90159-06082	SCREW, WITH WASHER	2	2	2	2	
10	2GU-2171L-00	MOLE, SIDE COVER 1	2	2	2	2	
11	2GU-21871-00	TANK, RECOVERY	1	1	1	1	
12	90480-48399	GROMMET	1	1	1	1	
13	10V-21875-00	CAP	1	1	1	1	
14	90445-084J0	HOSE (L1500)	1	1	1	1	
15	90467-08075	CLIP	1	1	1	1	
16	90445-090F7	HOSE (L1150)	1	1	1	1	
17	90467-08003	CLIP	2	2	2	2	

FIG. 19 REAR ARM

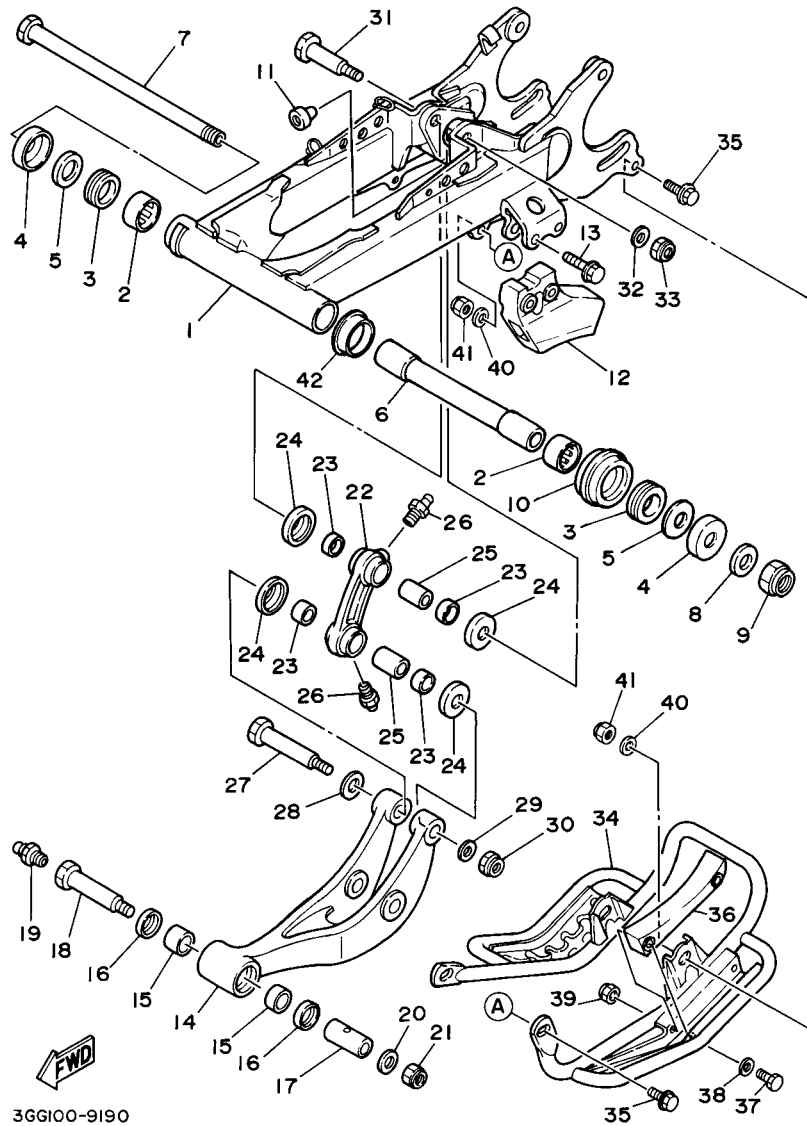

REF. NO.	PART NO.	DESCRIPTION	U49	CAN	FRA	OCE	REMARKS
1	3GG-22110-00-P0	REAR ARM COMP.	1	1	1	1	S8
2	93317-22237	BEARING	2	2	2	2	
3	93108-35004	OIL SEAL (35-41-8)	2	2	2	2	
4	2K6-22128-01	COVER, THRUST 1	2	2	2	2	
5	90201-244A9	WASHER, PLATE (2.05T)	2	2	2	2	
6	2GU-22184-00	BUSH	1	1	1	1	
7	2GU-22141-00	SHAFT, PIVOT	1	1	1	1	
8	90201-160F6	WASHER, PLATE	1	1	1	1	
9	90185-16127	NUT, SELF-LOCKING	1	1	1	1	
10	2GU-22151-10	SEAL, GUARD	1	1	1	1	
11	4N0-27114-00	STOPPER, MAIN STAND	1	1	1	1	
12	5X4-22199-00	SUPPORT, CHAIN	1	1	1	1	
13	95807-08040	BOLT, FLANGE	2	2	2	2	
14	1UY-2217A-00	ARM, RELAY	1	1	1	1	
15	90383-20033	BUSH, FORMED	2	2	2	2	
16	93109-20076	OIL SEAL	2	2	2	2	
17	90387-125N9	COLLAR	1	1	1	1	
18	90109-10752	BOLT	1	1	1	1	
19	93700-06004	NIPPLE, GREASE	1	1	1	1	
20	90201-10430	WASHER, PLATE	1	1	1	1	
21	90185-10120	NUT, SELF-LOCKING	1	1	1	1	
22	3GG-2217F-00	ROD, CONNECTING 1	1	1	1	1	
23	90383-20032	BUSH, FORMED	4	4	4	4	
24	23X-22129-00	COVER, THRUST 2	4	4	4	4	
25	90387-125N8	COLLAR	2	2	2	2	
26	93700-06004	NIPPLE, GREASE	2	2	2	2	
27	90109-102A6	BOLT	1	1	1	1	

FIG. 19 REAR ARM

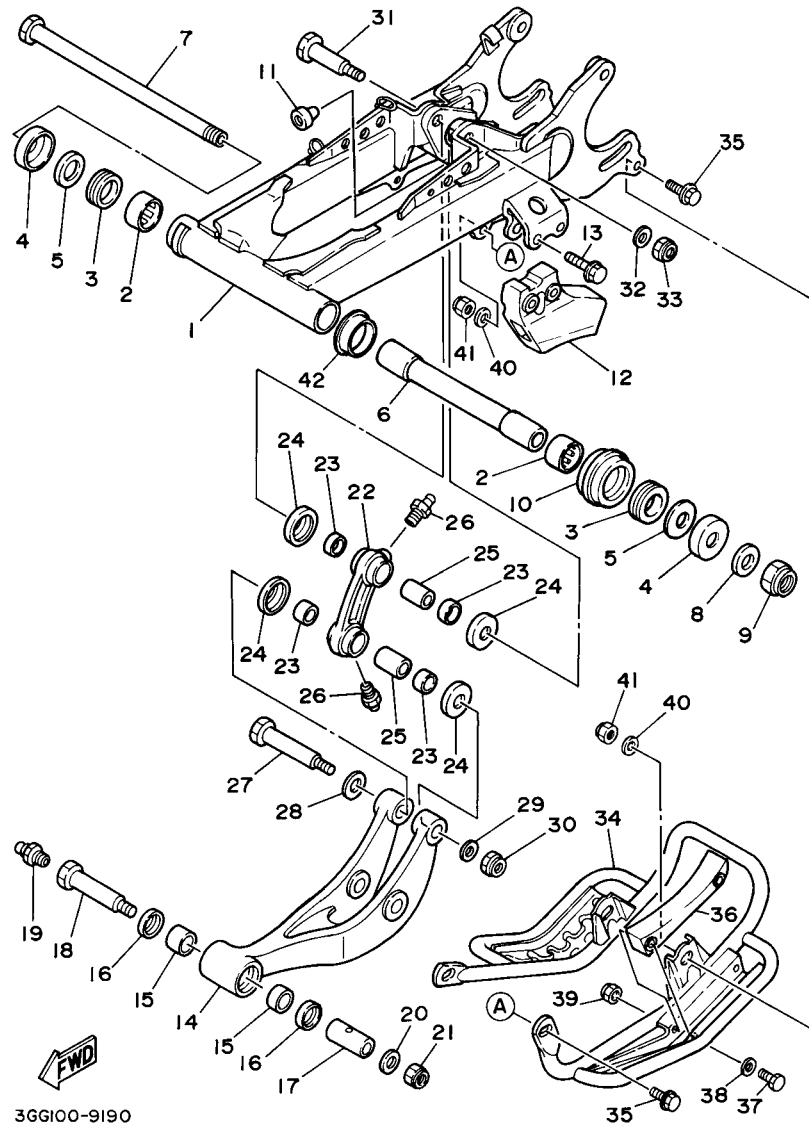

REF. NO.	PART NO.	DESCRIPTION	U49	CAN	FRA	OCE	REMARKS
28	90201-120E6	WASHER, PLATE	1	1	1	1	
29	90201-100E9	WASHER, PLATE	1	1	1	1	
30	90185-10120	NUT, SELF-LOCKING	1	1	1	1	
31	90109-10654	BOLT	1	1	1	1	
32	90201-10430	WASHER, PLATE	1	1	1	1	
33	90185-10120	NUT, SELF-LOCKING	1	1	1	1	
34	3GG-2219X-00	COVER	1	1	1	1	
35	95827-08020	BOLT, FLANGE	4	4	4	4	
36	2GU-22153-00	GUARD, CHAIN	1	1	1	1	
37	97027-06045	BOLT	2	2	2	2	
38	92907-06600	WASHER, PLATE	2	2	2	2	
39	95607-06100	NUT, U	2	2	2	2	
40	92907-08600	WASHER, PLATE	4	4	4	4	
41	95607-08100	NUT, U	4	4	4	4	
42	2GU-22155-00	PIPE	1	1	1	1	

FIG. 20 REAR SUSPENSION

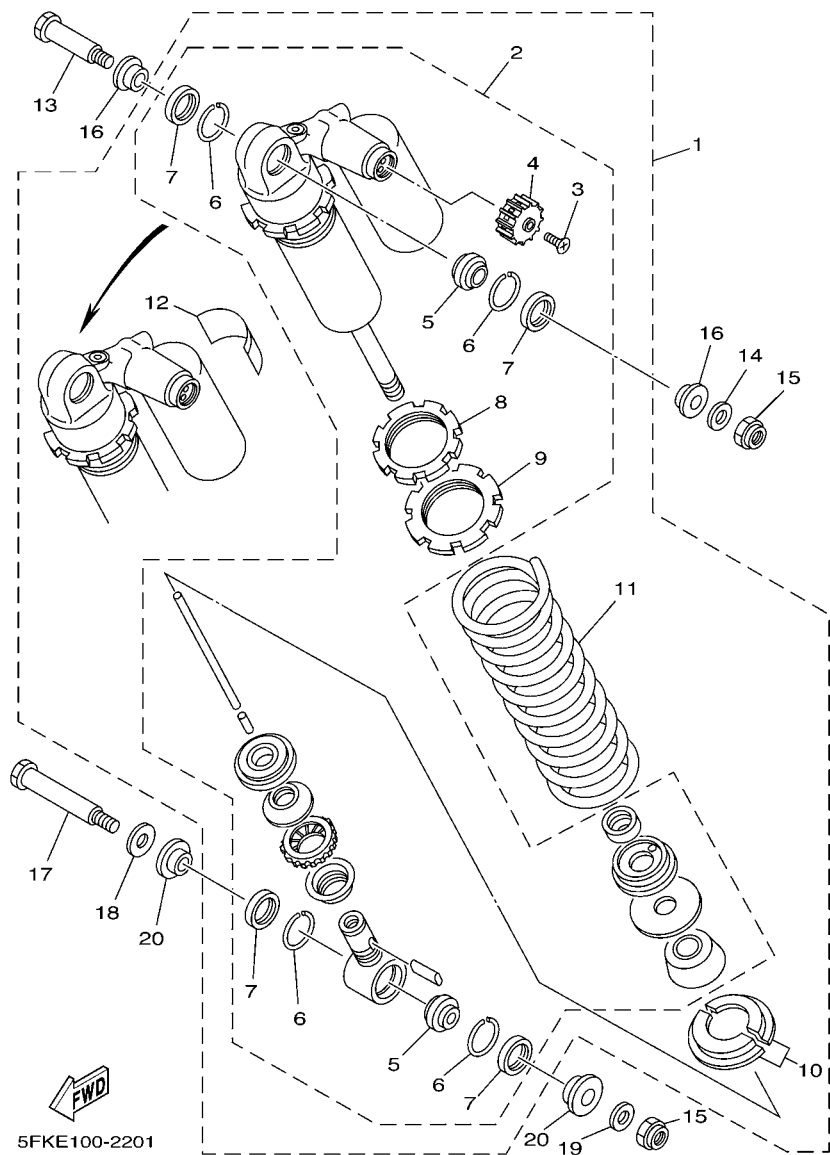

REF. NO.	PART NO.	DESCRIPTION	U49	CAN	FRA	OCE	REMARKS
1	3GG-22210-42-33	SHOCK ABSORBER ASSY, REAR	1				YB
	3GG-22210-52-33	SHOCK ABSORBER ASSY, REAR		1			YB
	3GG-22210-72-33	SHOCK ABSORBER ASSY, REAR			1	1	YB
2	3GG-22201-42	.DAMPER SUB ASSY	1	1	1	1	
3	98507-04006	..SCREW, PAN HEAD	1	1	1	1	
4	CA4-22464-00	..KNOB, CONTROL	1	1	1	1	
5	93399-99916	..BEARING	2	2	2	2	
6	93440-30113	..CIRCLIP	4	4	4	4	
7	93104-18077	..OIL SEAL	4	4	4	4	
8	1RK-22215-00	..RING, COVER	1	1	1	1	
9	38W-22223-00	..SEAT, SPRING LOWER	1	1	1	1	
10	22W-22214-01	.GUIDE, SPRING 1	1	1	1	1	
11	38W-22212-10-33	.SPRING	1	1	1	1	YB
12	4AA-22259-80	.LABEL, WARNING	1				
	4AA-22259-70	.LABEL, WARNING		1			
	4AA-22259-40	.LABEL, WARNING			1	1	
13	90109-10704	BOLT	1	1	1	1	
14	90201-10430	WASHER, PLATE	1	1	1	1	
15	90185-10120	NUT, SELF-LOCKING	2	2	2	2	
16	90387-127G8	COLLAR	2	2	2	2	
17	90109-102A6	BOLT	1	1	1	1	
18	90201-120E6	WASHER, PLATE	1	1	1	1	
19	90201-100E9	WASHER, PLATE	1	1	1	1	
20	90387-126H8	COLLAR	2	2	2	2	

FIG. 21 STEERING

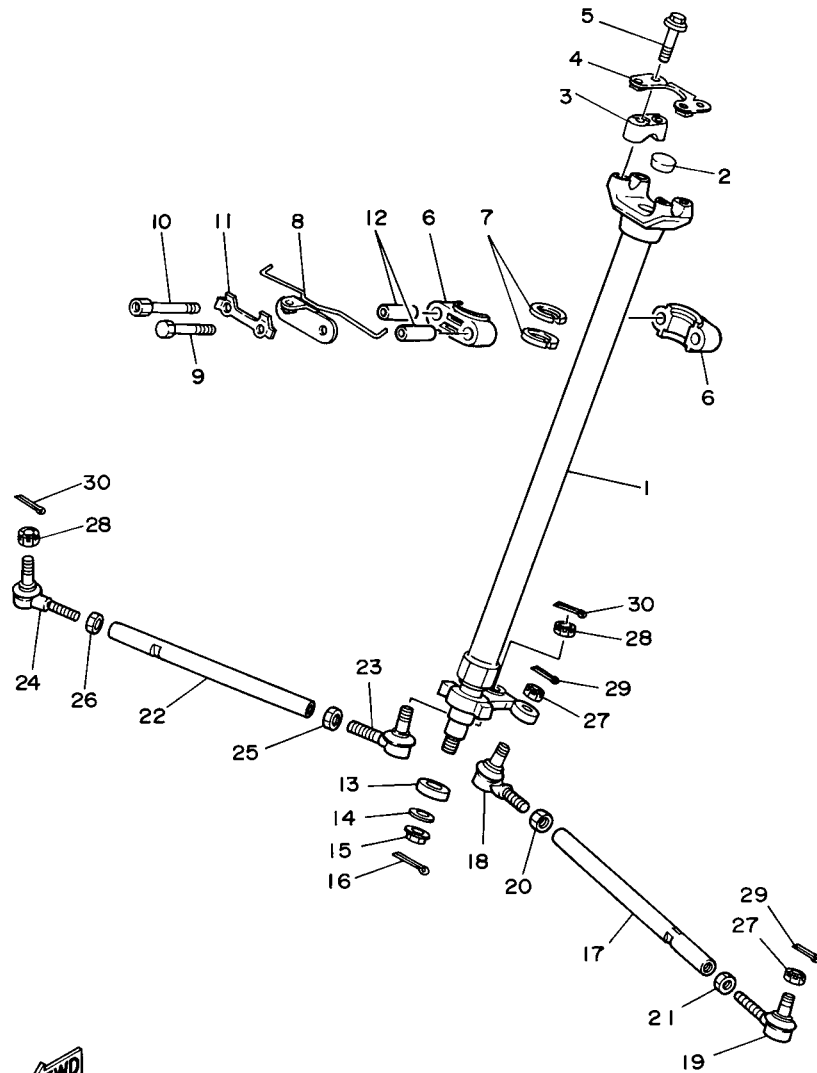

36GS100-7220

REF. NO.	PART NO.	DESCRIPTION	U49	CAN	FRA	OCE	REMARKS
1	3GG-23813-01	COLUMN, STEERING 2	1	1	1	1	
2	90336-28053	PLUG, TAPER	1	1	1	1	
3	8K1-23814-00	HOLDER, HANDLE	2	2	2	2	
4	2GU-2629K-00	STAY	1	1	1	1	
5	95827-08035	BOLT, FLANGE	4	4	4	4	
6	1UY-23812-00	PLANE BEARING, STEERING	2	2	2	2	
7	93112-31011	OIL SEAL	2	2	2	2	
8	2GU-23868-00	BRACKET, STEERING LOWER	1	1	1	1	
9	97027-08060	BOLT	1	1	1	1	
10	90109-082E9	BOLT	1	1	1	1	
11	1UY-23894-01	WASHER, LOCK 1	1	1	1	1	
12	90387-090R0	COLLAR	2	2	2	2	
13	90387-176R6	COLLAR	1	1	1	1	
14	90201-10774	WASHER, PLATE	1	1	1	1	
15	90185-10115	NUT, SELF-LOCKING	1	1	1	1	
16	91401-20020	PIN, COTTER	1	1	1	1	
17	2GU-23831-01	ROD, TIE	1	1	1	1	
18	1UY-23841-01	JOINT, UNIVERSAL 1	1	1	1	1	
19	1UY-23845-01	JOINT, UNIVERSAL 2	1	1	1	1	
20	95307-10700	NUT	1	1	1	1	
21	90170-10186	NUT	1	1	1	1	(L.H. THREAD)
22	2GU-23831-01	ROD, TIE	1	1	1	1	
23	1UY-23841-01	JOINT, UNIVERSAL 1	1	1	1	1	
24	1UY-23845-01	JOINT, UNIVERSAL 2	1	1	1	1	
25	95307-10700	NUT	1	1	1	1	
26	90170-10186	NUT	1	1	1	1	(L.H. THREAD)
27	90171-10046	NUT, CASTLE	2	2	2	2	

FIG. 21 STEERING

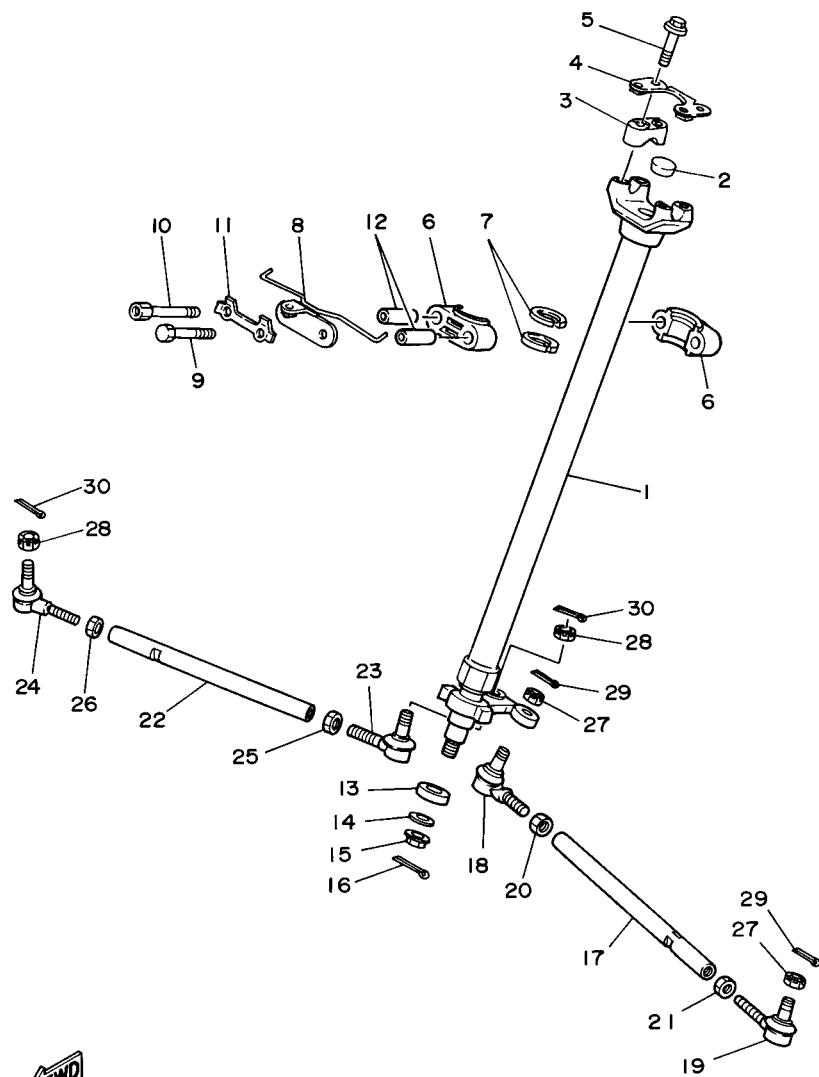

36GS100-7220

REF. NO.	PART NO.	DESCRIPTION	U49	CAN	FRA	OCE	REMARKS
28	90171-10046	NUT, CASTLE	2	2	2	2	
29	91401-20020	PIN, COTTER	2	2	2	2	
30	91401-20020	PIN, COTTER	2	2	2	2	

FIG. 22 FRONT SUSPENSION & WHEEL

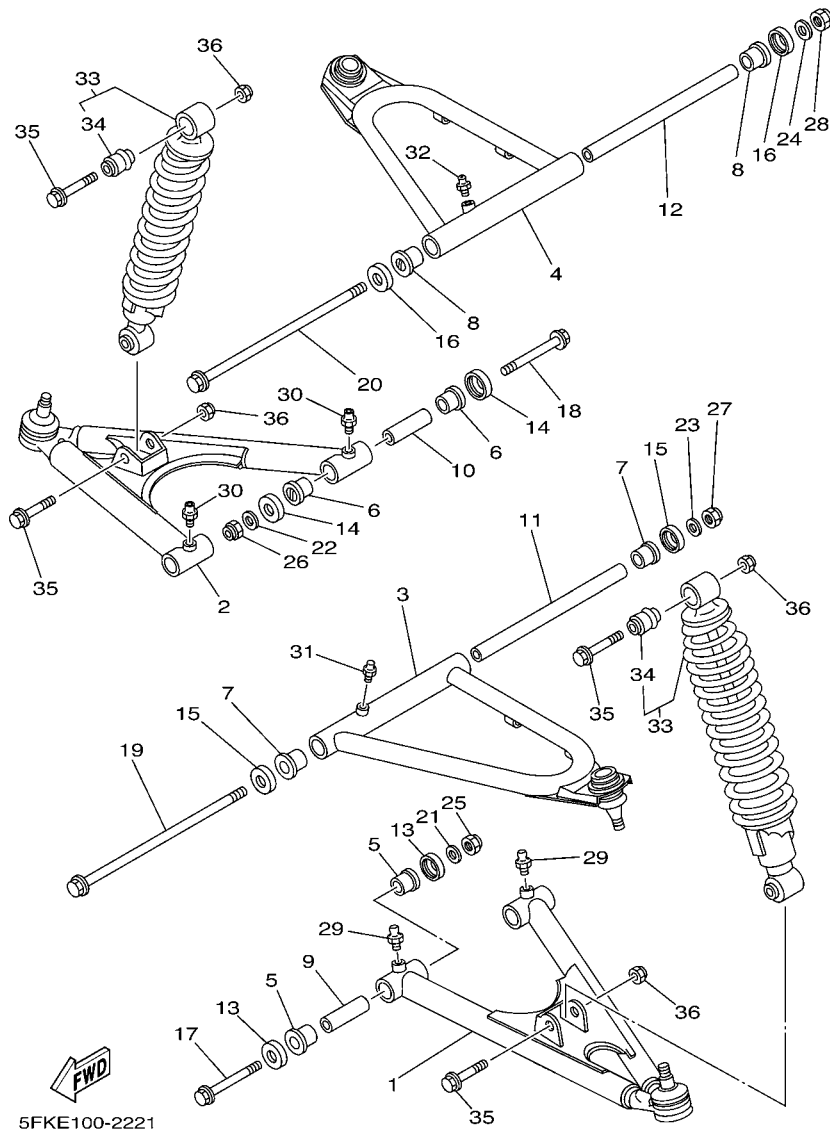

REF. NO.	PART NO.	DESCRIPTION	U49	CAN	FRA	OCE	REMARKS
1	2GU-23570-00-P0	FRONT LOWER ARM COMP. (LEFT)	1	1	1	1	MBL2
2	2GU-23580-00-P0	FRONT LOWER ARM COMP. (RIGHT)	1	1	1	1	MBL2
3	3GG-23540-00-P0	FRONT UPPER ARM COMP. (LEFT)	1	1	1	1	MBL2
4	3GG-23550-00-P0	FRONT UPPER ARM COMP. (RIGHT)	1	1	1	1	MBL2
5	90381-15088	BUSH, SOLID	4	4	4	4	
6	90381-15088	BUSH, SOLID	4	4	4	4	
7	90381-15088	BUSH, SOLID	2	2	2	2	
8	90381-15088	BUSH, SOLID	2	2	2	2	
9	90387-101R3	COLLAR	2	2	2	2	
10	90387-101R3	COLLAR	2	2	2	2	
11	90387-100Y6	COLLAR	1	1	1	1	
12	90387-100Y6	COLLAR	1	1	1	1	
13	1UY-23517-00	COVER, THRUST 1	4	4	4	4	
14	1UY-23517-00	COVER, THRUST 1	4	4	4	4	
15	1UY-23517-00	COVER, THRUST 1	2	2	2	2	
16	1UY-23517-00	COVER, THRUST 1	2	2	2	2	
17	90105-10034	BOLT, FLANGE	2	2	2	2	
18	90105-10034	BOLT, FLANGE	2	2	2	2	
19	90105-10651	BOLT, FLANGE	1	1	1	1	
20	90105-10651	BOLT, FLANGE	1	1	1	1	
21	90201-10430	WASHER, PLATE	2	2	2	2	
22	90201-10430	WASHER, PLATE	2	2	2	2	
23	90201-10430	WASHER, PLATE	1	1	1	1	
24	90201-10430	WASHER, PLATE	1	1	1	1	
25	90185-10060	NUT, SELF-LOCKING	2	2	2	2	
26	90185-10060	NUT, SELF-LOCKING	2	2	2	2	
27	90185-10060	NUT, SELF-LOCKING	1	1	1	1	

FIG. 23 FUEL TANK

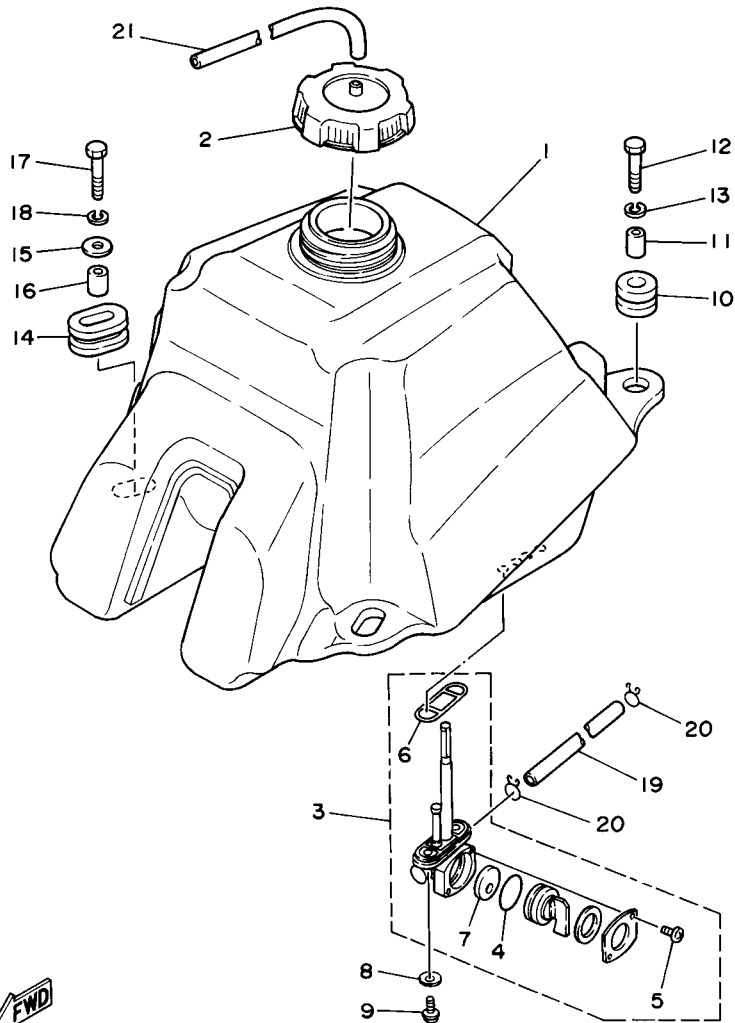

3662100-0230

REF. NO.	PART NO.	DESCRIPTION	U49	CAN	FRA	OCE	REMARKS
1	2GU-24110-00	FUEL TANK COMP.	1	1	1	1	
2	5KM-24610-00	CAP ASSY	1	1	1	1	
3	2GU-24500-02	FUEL COCK ASSY 1	1	1	1	1	
4	3AJ-24534-01	.SEAL, COCK	1	1	1	1	
5	98507-03008	.SCREW, PAN HEAD	2	2	2	2	
6	4X8-24512-00	.O-RING	1	1	1	1	
7	3AC-24523-00	.VALVE PACKING	1	1	1	1	
8	90202-05193	WASHER, PLATE	2	2	2	2	
9	90149-06011	SCREW	2	2	2	2	
10	90480-18290	GROMMET	2	2	2	2	
11	90387-066J1	COLLAR	2	2	2	2	
12	97027-06030	BOLT	2	2	2	2	
13	92907-06100	WASHER, SPRING	2	2	2	2	
14	90480-01400	GROMMET	2	2	2	2	
15	90201-060L5	WASHER, PLATE	2	2	2	2	
16	90387-07598	COLLAR	2	2	2	2	
17	97027-06030	BOLT	2	2	2	2	
18	92907-06100	WASHER, SPRING	2	2	2	2	
19	90445-13693	HOSE (L166)	1	1	1	1	
20	90467-11106	CLIP	2	2	2	2	
21	90445-084J1	HOSE (L420)	1	1	1	1	

FIG. 24 SEAT

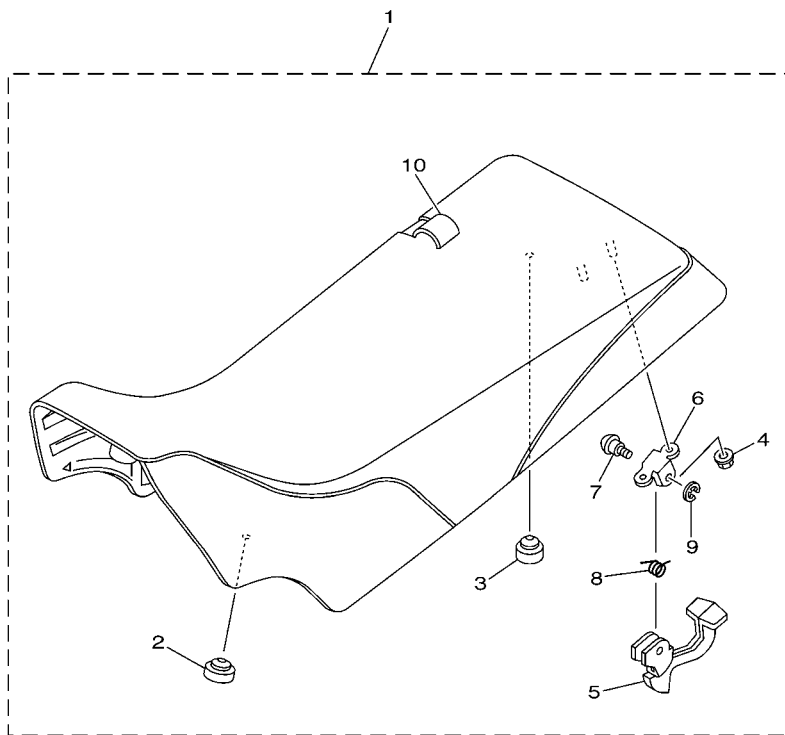

REF. NO.	PART NO.	DESCRIPTION	U49	CAN	FRA	OCE	REMARKS
1	5FK-24710-E0	SINGLE SEAT ASSY	1	1	1	1	
2	22W-24741-00	.PAD, SEAT	2	2	2	2	
3	371-27114-00	.STOPPER, MAIN STAND	2	2	2	2	
4	95707-06500	.NUT, FLANGE	2	2	2	2	
5	3GD-24776-00	.LEVER, SEAT	1	1	1	1	
6	4K0-24775-00	.BRACKET, SEAT LEVER	1	1	1	1	
7	4K0-24774-01	.PIN	1	1	1	1	
8	90508-20454	.SPRING, TORSION	1	1	1	1	
9	93430-20454	.CIRCLIP	1	1	1	1	
10	5FK-2470F-E0	.SEAT COVER COMP.	1	1	1	1	

5FKJ100-B240

FIG. 25 FRONT WHEEL

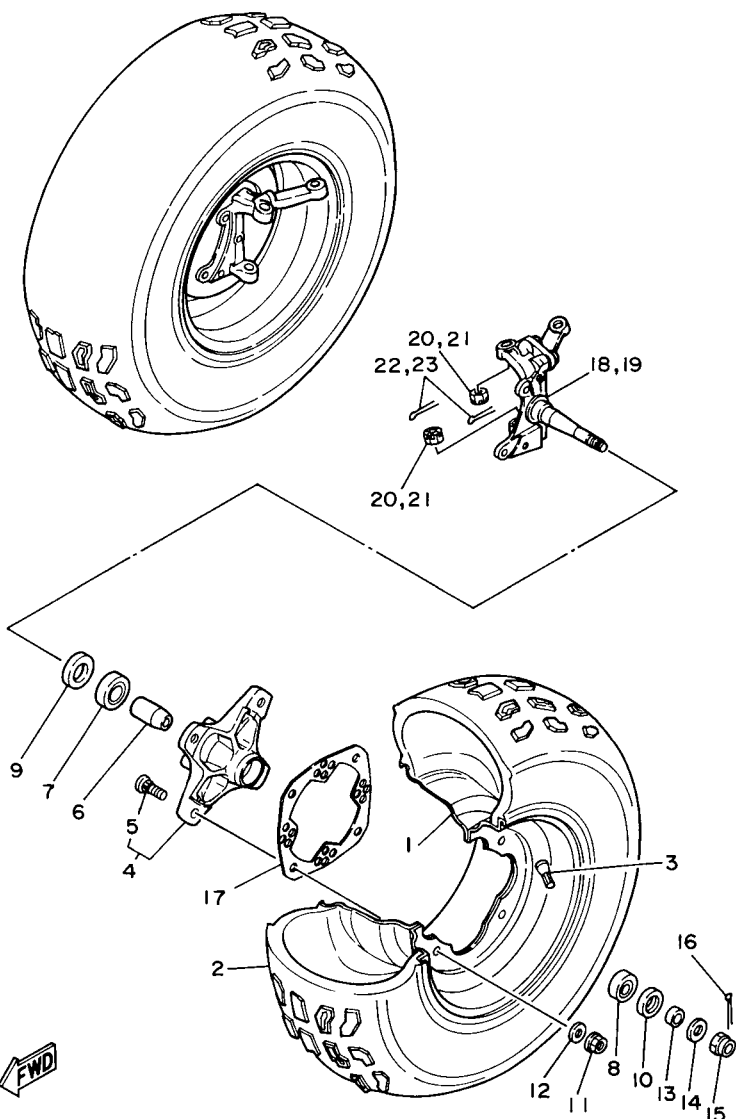

36GM100-6250

REF. NO.	PART NO.	DESCRIPTION	U49	CAN	FRA	OCE	REMARKS
1	2XK-25180-10-HM	WHEEL COMP.	2	2	2	2	AMS
2	94107-10012	TIRE (AT21X7-10 KT851B)	2	2	2	2	DUNLOP
3	93900-00022	VALVE, RIM (TR413)	2	2	2	2	TAIHEIYO
4	3GD-25111-01	HUB, FRONT	2	2	2	2	
5	90114-10007	.BOLT, SERRATION	4	4	4	4	
6	1UY-25117-00	SPACER, BEARING	2	2	2	2	
7	93306-00406	BEARING (B6004Z)	2	2	2	2	UR NTN
	93306-00438	BEARING	2	2	2	2	UR NIHONSEIKO
8	93306-20227	BEARING	2	2	2	2	
9	93105-26026	OIL SEAL	2	2	2	2	
10	93102-22216	OIL SEAL	2	2	2	2	
11	95707-10500	NUT, FLANGE	8	8	8	8	
12	92907-10200	WASHER, PLAIN	8	8	8	8	
13	90387-150R1	COLLAR	2	2	2	2	
14	90201-14586	WASHER, PLATE	2	2	2	2	
15	90171-14020	NUT, CASTLE	2	2	2	2	
16	91401-30025	PIN, SPLIT	2	2	2	2	
17	3GD-25127-10	COVER, PLATE	2	2	2	2	
18	3GD-23501-00	STEERING KNUCKLE ASSY (LEFT)	1	1	1	1	
19	3GD-23502-00	STEERING KNUCKLE ASSY (RIGHT)	1	1	1	1	
20	90171-10046	NUT, CASTLE	2	2	2	2	
21	90171-10046	NUT, CASTLE	2	2	2	2	
22	91401-20020	PIN, COTTER	2	2	2	2	
23	91401-20020	PIN, COTTER	2	2	2	2	

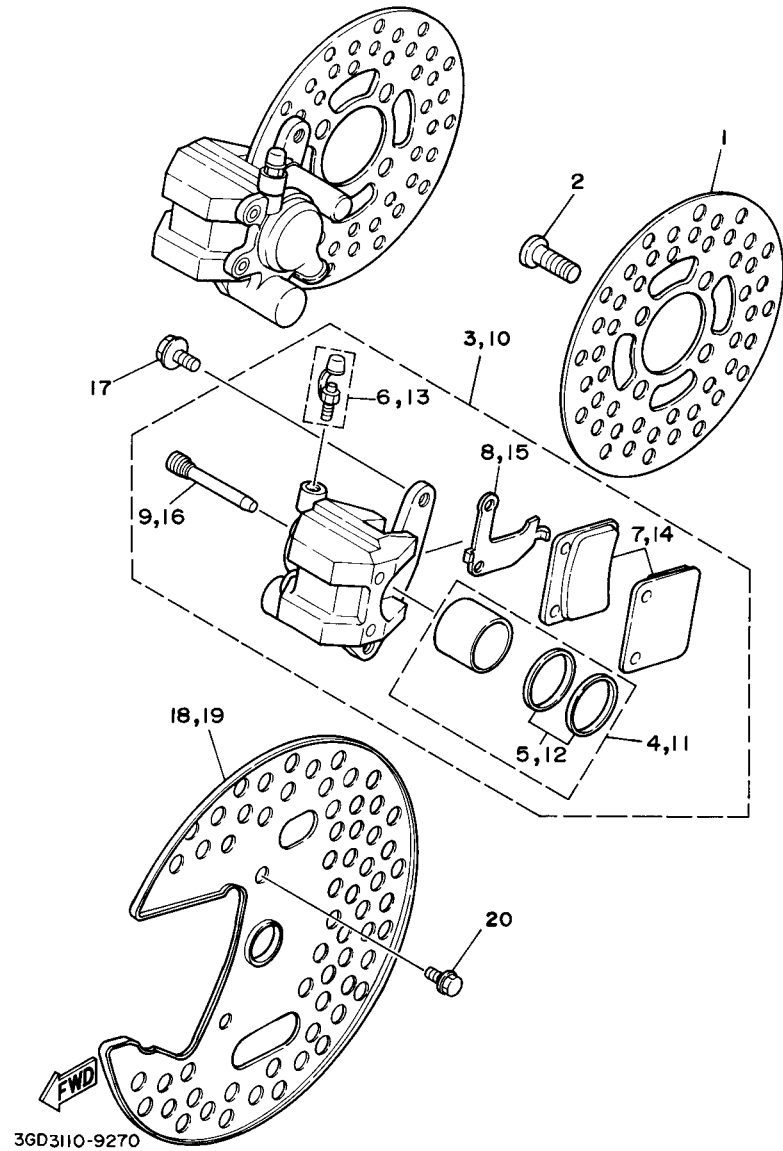
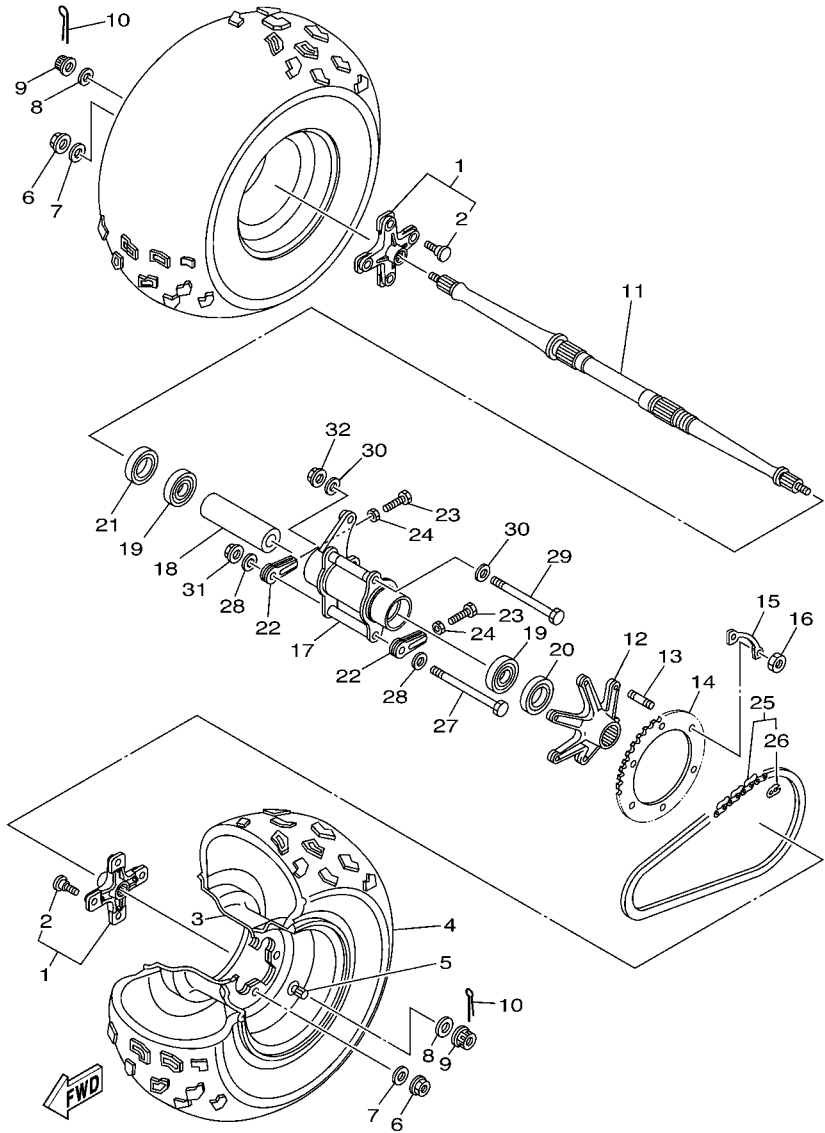

FIG. 26 FRONT BRAKE CALIPER

REF. NO.	PART NO.	DESCRIPTION	U49	CAN	FRA	OCE	REMARKS
1	3GD-2582T-10	DISC, BRAKE (LEFT)	2	2	2	2	
2	90149-08268	SCREW	8	8	8	8	
3	5LP-2580T-00	CALIPER ASSY (LEFT)	1	1	1	1	
4	3GD-W0057-00	.PISTON ASSY, CALIPER	1	1	1	1	
5	3GD-W0047-00	..CALIPER SEAL KIT	1	1	1	1	
6	1UY-W0048-50	.BLEED SCREW KIT	1	1	1	1	
7	5LP-W0045-00	.BRAKE PAD KIT	1	1	1	1	
8	3GD-25827-00	.SHIM, CALIPER	1	1	1	1	
9	3GD-25933-00	.PIN, PAD	2	2	2	2	
10	5LP-2580U-00	CALIPER ASSY (RIGHT)	1	1	1	1	
11	3GD-W0057-00	.PISTON ASSY, CALIPER	1	1	1	1	
12	3GD-W0047-00	..CALIPER SEAL KIT	1	1	1	1	
13	1UY-W0048-50	.BLEED SCREW KIT	1	1	1	1	
14	5LP-W0045-00	.BRAKE PAD KIT	1	1	1	1	
15	3GD-25828-00	.SHIM, CALIPER	1	1	1	1	
16	3GD-25933-00	.PIN, PAD	2	2	2	2	
17	90105-08538	BOLT, FLANGE	4	4	4	4	
18	3GD-2514A-10	RING, WHEEL 1 (LEFT)	1	1	1	1	
19	3GD-2515A-10	RING, WHEEL 2 (RIGHT)	1	1	1	1	
20	95807-06010	BOLT, FLANGE	4	4	4	4	



5FKE100-2270

FIG. 27 REAR WHEEL

REF. NO.	PART NO.	DESCRIPTION	U49	CAN	FRA	OCE	REMARKS
1	5LP-25383-10	COLLAR, WHEEL	2	2	2	2	
2	90114-10009	.BOLT, SERRATION	4	4	4	4	
3	2XK-25390-01-HM	REAR WHEEL COMP.	2	2	2	2	AMS
4	94110-09011	TIRE (AT20X10-9 KT877A)	2	2	2	2	DUNLOP
5	93900-00022	VALVE, RIM (TR413)	2	2	2	2	TAIHEIYO
6	95707-10500	NUT, FLANGE	8	8	8	8	
7	92907-10200	WASHER, PLAIN	8	8	8	8	
8	90201-14226	WASHER, PLATE	2	2	2	2	
9	90171-14037	NUT, CASTLE	2	2	2	2	
10	91401-30030	PIN, COTTER	2	2	2	2	
11	38W-25381-02	AXLE, WHEEL	1	1	1	1	
12	2XJ-25386-00	COLLAR, SPROCKET AXLE	1	1	1	1	
13	90116-08507	BOLT, STUD	6	6	6	6	
14	2XJ-25441-21	SPROCKET, DRIVEN (41T)	1	1	1	1	
15	2XJ-25412-00	WASHER	3	3	3	3	
16	90170-08258	NUT	6	6	6	6	
17	3GG-25311-01-P1	HUB, REAR	1	1	1	1	S8
18	90560-35263	SPACER	1	1	1	1	
19	93306-00705	BEARING	2	2	2	2	
20	93102-42260	OIL SEAL	1	1	1	1	
21	93102-43341	OIL SEAL	1	1	1	1	
22	2XJ-25388-00	PULLER, CHAIN 1	2	2	2	2	
23	90101-08777	BOLT	2	2	2	2	
24	95307-08600	NUT	2	2	2	2	
25	9Y581-87103	CHAIN (DID520V-103L)	1	1	1	1	
26	94681-87011	.JOINT, CHAIN (DID520V FJ)	1	1	1	1	
27	90101-10685	BOLT	1	1	1	1	

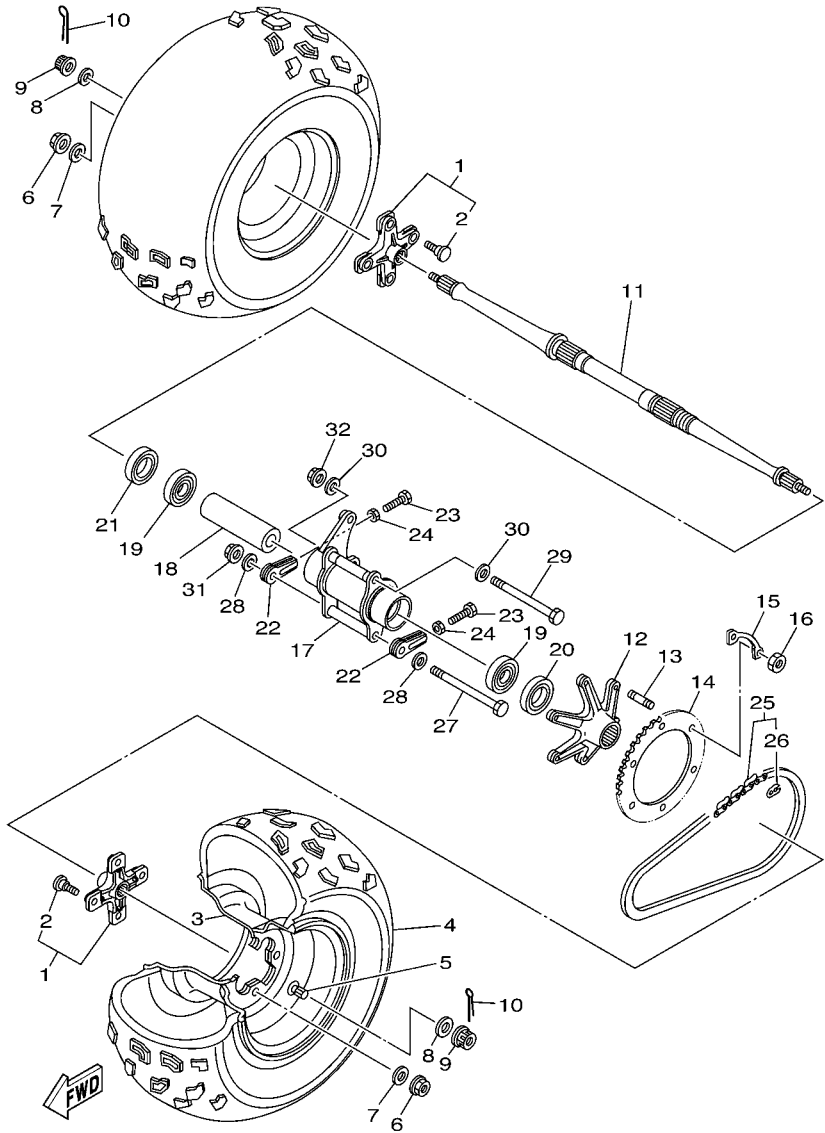
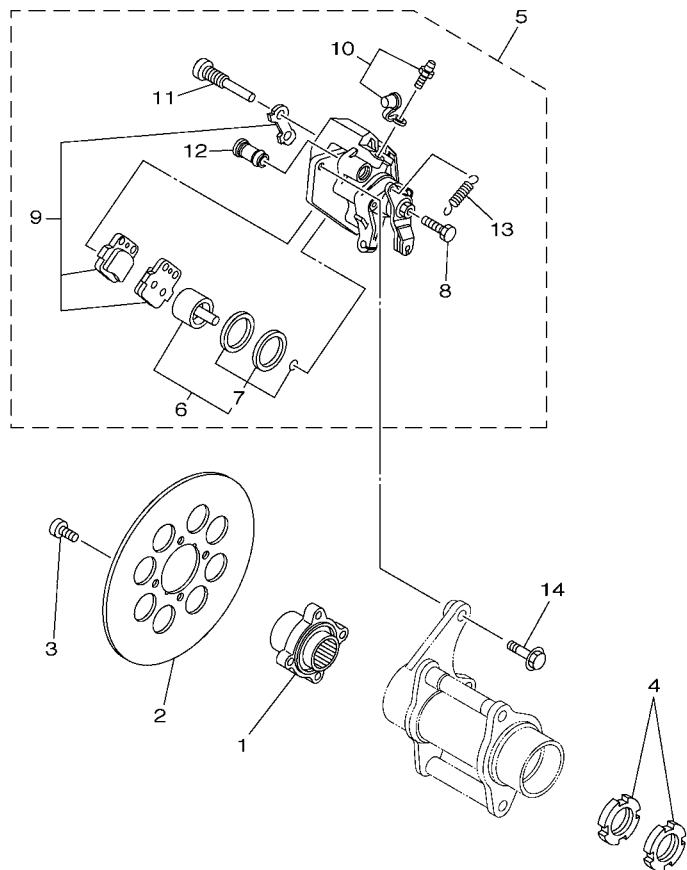

FIG. 27 REAR WHEEL

REF. NO.	PART NO.	DESCRIPTION	U49	CAN	FRA	OCE	REMARKS
28	90201-106F2	WASHER, PLATE	2	2	2	2	
29	90101-12694	BOLT	1	1	1	1	
30	90201-126A7	WASHER, PLATE	2	2	2	2	
31	90179-10247	NUT	1	1	1	1	
32	90179-12588	NUT	1	1	1	1	

FIG. 28 REAR BRAKE CALIPER



REF. NO.	PART NO.	DESCRIPTION	U49	CAN	FRA	OCE	REMARKS
1	2GU-25712-00	BRACKET, DISC	1	1	1	1	
2	5FK-2582W-00	DISK, REAR BRAKE 2	1	1	1	1	
3	90109-081F0	BOLT	4	4	4	4	
4	90170-33376	NUT	2	2	2	2	
5	1UY-2580W-00	CALIPER ASSY, REAR 2	1	1	1	1	
6	1UY-W0057-50	.PISTON ASSY, CALIPER	1	1	1	1	
7	1UY-W0047-50	.CALIPER SEAL KIT	1	1	1	1	
8	1UY-25972-51	.ADJUSTBOLT	1	1	1	1	
9	1UY-W0046-00	.BRAKE PAD KIT 2	1	1	1	1	
10	1UY-W0048-50	.BLEED SCREW KIT	1	1	1	1	
11	1UY-25924-51	.PIN, PAD	2	2	2	2	
12	1UY-25917-51	.BOOT, CALIPER	2	2	2	2	
13	1UY-25977-51	.SPRING, RETURN	1	1	1	1	
14	90105-08440	BOLT, FLANGE	2	2	2	2	

5FKJ100-B280

FIG. 29 STEERING HANDLE & CABLE

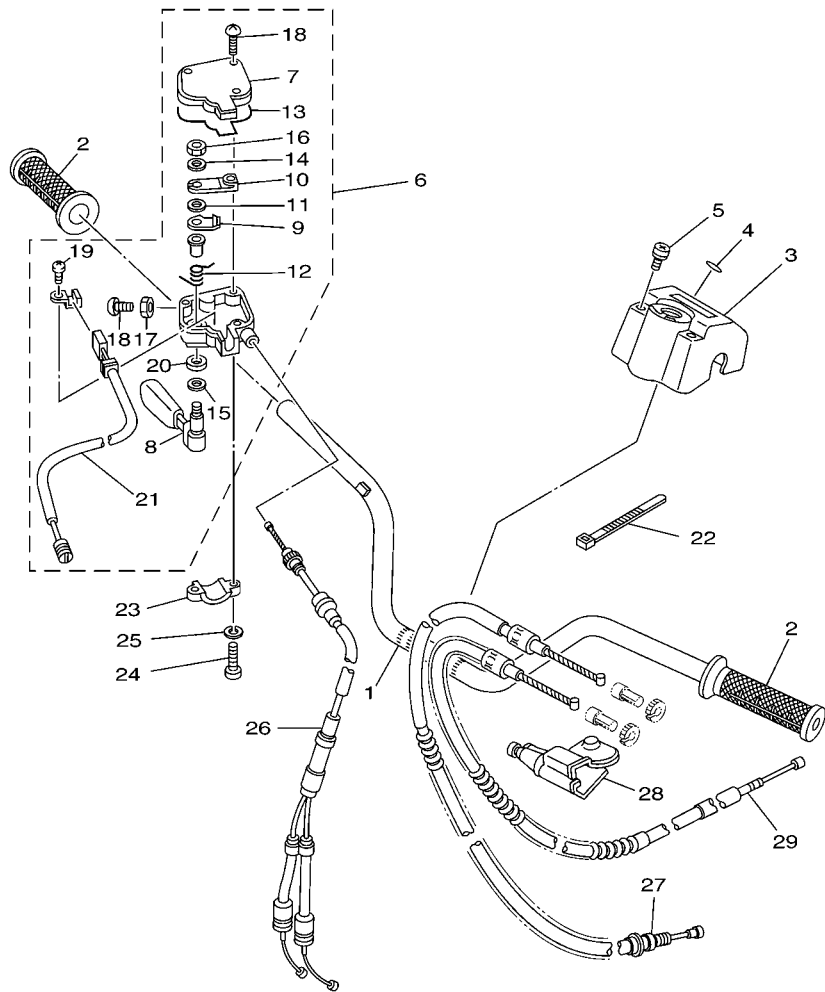

5FKJ100-B290

REF. NO.	PART NO.	DESCRIPTION	U49	CAN	FRA	OCE	REMARKS
1	5LP-26111-30	HANDLEBAR	1	1	1	1	
2	5LP-26241-00	GRIP	2	2	2	2	
3	2GU-26124-01	PROTECTOR, HANDLEBAR	1	1	1	1	
4	5GT-2836B-10	TUNING FORK MARK	1	1	1	1	
5	90159-06093	SCREW, WITH WASHER	2	2	2	2	
6	3GG-26250-00	THROTTLE LEVER ASSY	1	1	1	1	
7	2GU-2628F-00	.CAP, GEAR	1	1	1	1	
8	2GU-2625G-01	.LEVER, THROTTLE	1	1	1	1	
9	2GU-2625H-00	.ARM, THROTTLE	1	1	1	1	
10	2GU-2625J-00	.ARM, THROTTLE 2	1	1	1	1	
11	2GU-26259-00	.COLLAR	1	1	1	1	
12	2GU-26314-00	.SPRING	1	1	1	1	
13	2GU-2628G-00	.GASKET	1	1	1	1	
14	2GU-26398-00	.WASHER	1	1	1	1	
15	1NV-26129-00	.WASHER	1	1	1	1	
16	95602-05100	.NUT, U	1	1	1	1	
17	95306-05700	.NUT	1	1	1	1	
18	98506-05020	.SCREW, PAN HEAD	4	4	4	4	
19	98902-03006	.SCREW, BIND	1	1	1	1	
20	93104-09025	.OIL SEAL	1	1	1	1	
21	3GG-82567-00	.SWITCH, THROTTLE	1	1	1	1	
22	437-83936-01	BAND, SWITCH CORD	2	2	2	2	
23	4V4-82913-00	HOLDER, LEVER LOWER 1	1	1	1	1	
24	98507-05020	SCREW, PAN HEAD	2	2	2	2	
25	92907-05100	WASHER, SPRING	2	2	2	2	
26	2GU-26260-01	CABLE ASSY, THROTTLE & PUMP	1	1	1	1	
27	5FK-26335-00	CABLE, CLUTCH	1	1	1	1	

FIG. 29 STEERING HANDLE & CABLE

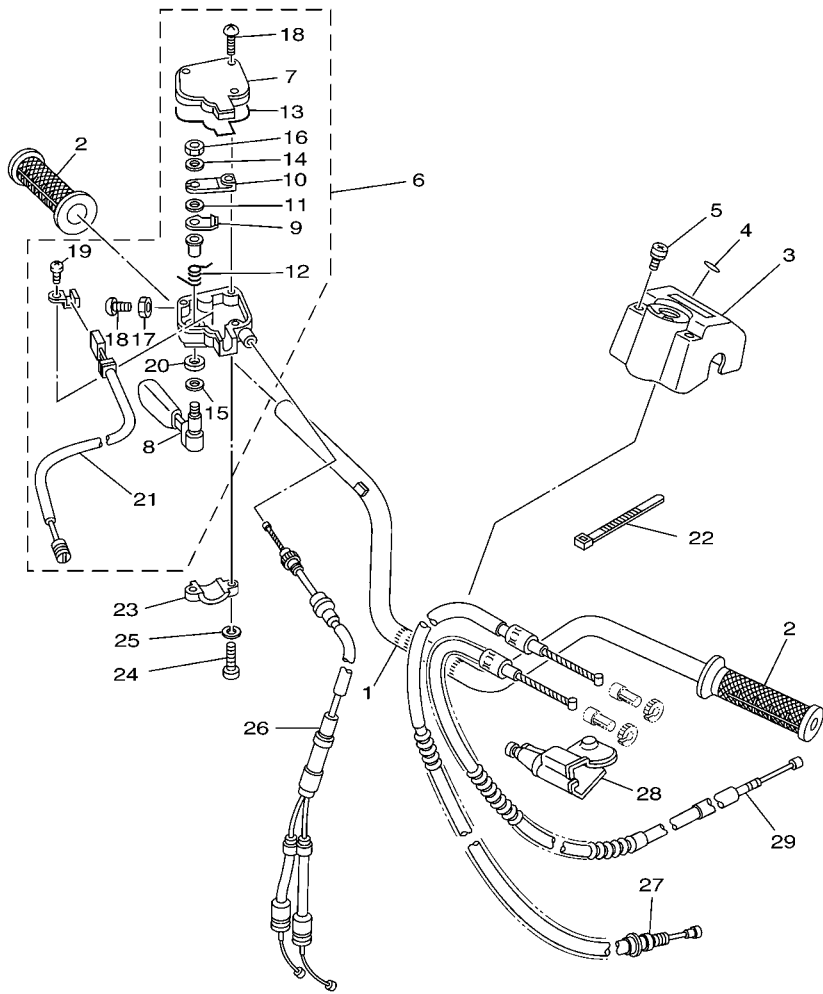

REF. NO.	PART NO.	DESCRIPTION	U49	CAN	FRA	OCE	REMARKS
28	1UY-2637A-01	COVER, HANDLE LEVER 2	1	1	1	1	
29	1UY-26341-02	CABLE, BRAKE	1	1	1	1	

5FKJ100-B290

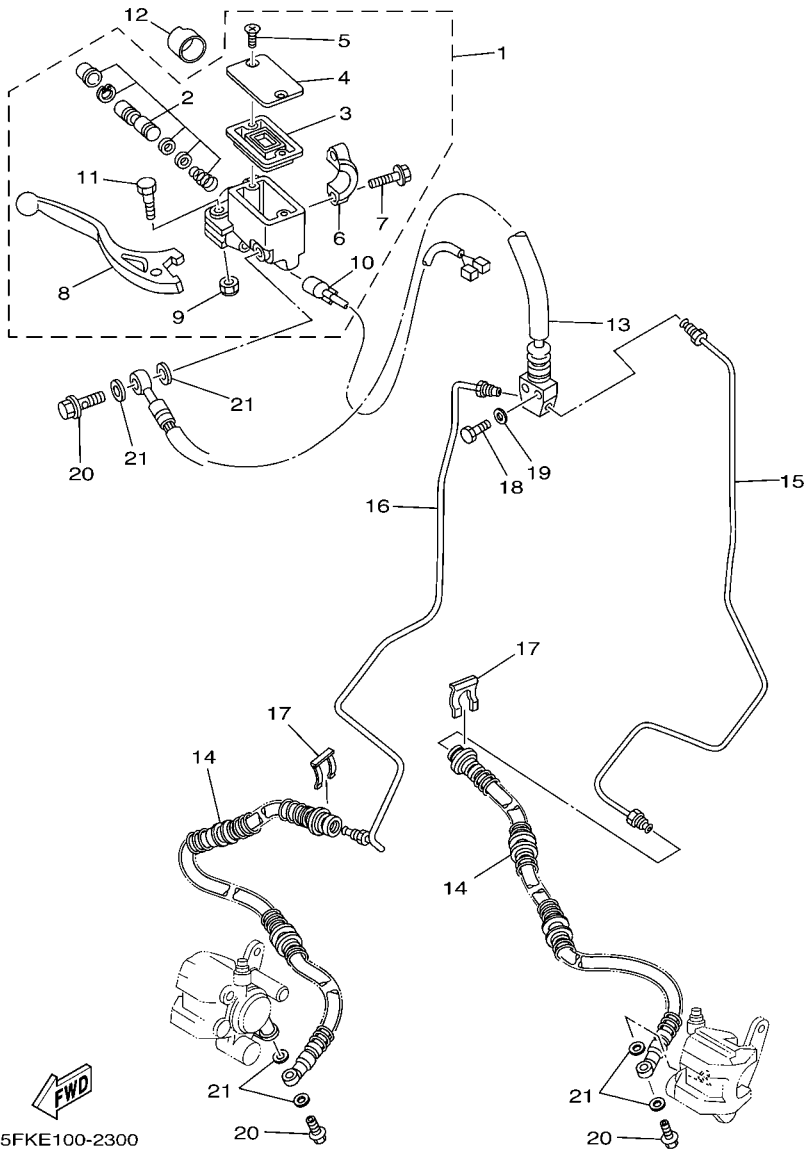
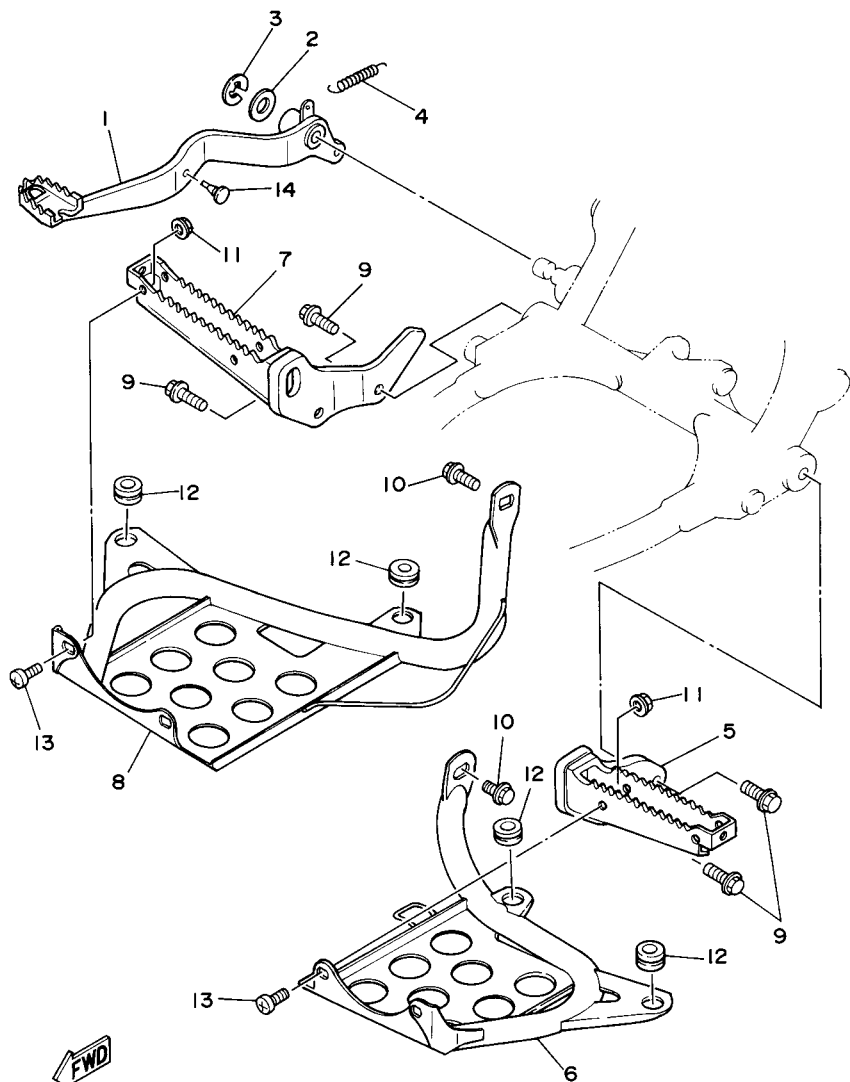

FIG. 30 FRONT MASTER CYLINDER

REF. NO.	PART NO.	DESCRIPTION	U49	CAN	FRA	OCE	REMARKS
1	5LP-2583T-01	MASTER CYLINDER ASSY	1	1	1	1	
2	5LP-W0041-00	.CYLINDER KIT, MASTER	1	1	1	1	
3	4L0-25854-00	.DIAPHRAGM, RESERVOIR	1	1	1	1	
4	5LP-25852-01	.CAP, RESERVOIR	1	1	1	1	
5	4NK-2589H-00	.SCREW	2	2	2	2	
6	5LP-25867-00	.BRACKET, MASTER CYLINDER	1	1	1	1	
7	5MV-25833-00	.BOLT, FITTING	2	2	2	2	
8	5LP-83922-00	.LEVER 2	1	1	1	1	
9	95604-06100	.NUT, U	1	1	1	1	
10	5LP-83980-00	.FRONT STOP SWITCH ASSY	1	1	1	1	
11	5MV-2589F-00	.BOLT, LEVER	1	1	1	1	
12	1UY-26259-00	COLLAR	1	1	1	1	
13	2GU-25872-02	HOSE, BRAKE 1	1	1	1	1	
14	3GG-25873-11	HOSE, BRAKE 2	2	2	2	2	
15	2GU-25871-00	PIPE, BRAKE	1	1	1	1	
16	2GU-25882-00	PIPE, BRAKE 2	1	1	1	1	
17	2GU-25866-00	CIRCLIP	2	2	2	2	
18	97027-08025	BOLT	1	1	1	1	
19	92907-08600	WASHER, PLATE	1	1	1	1	
20	90401-10159	BOLT, UNION	3	3	3	3	
21	90201-10118	WASHER, PLATE	6	6	6	6	



3GG2100-0310



FIG. 31 STAND & FOOTREST

REF. NO.	PART NO.	DESCRIPTION	U49	CAN	FRA	OCE	REMARKS
1	3GG-27211-00	PEDAL, BRAKE	1	1	1	1	
2	90201-15797	WASHER, PLATE	1	1	1	1	
3	93430-12008	CIRCLIP	1	1	1	1	
4	90506-20380	SPRING, TENSION	1	1	1	1	
5	3GG-27411-01	FOOTREST 1	1	1	1	1	
6	3GD-27445-00	PLATE 1	1	1	1	1	
7	3GG-27421-01	FOOTREST 2	1	1	1	1	
8	3GG-27446-00	PLATE 2	1	1	1	1	
9	95817-10025	BOLT, FLANGE	4	4	4	4	
10	95827-08016	BOLT, FLANGE	2	2	2	2	
11	95707-08500	NUT, FLANGE	4	4	4	4	
12	90480-18411	GROMMET	4	4	4	4	
13	92017-08016	BOLT, BUTTON HEAD	4	4	4	4	
14	90480-05201	GROMMET	1	1	1	1	

FIG. 34 GENERATOR

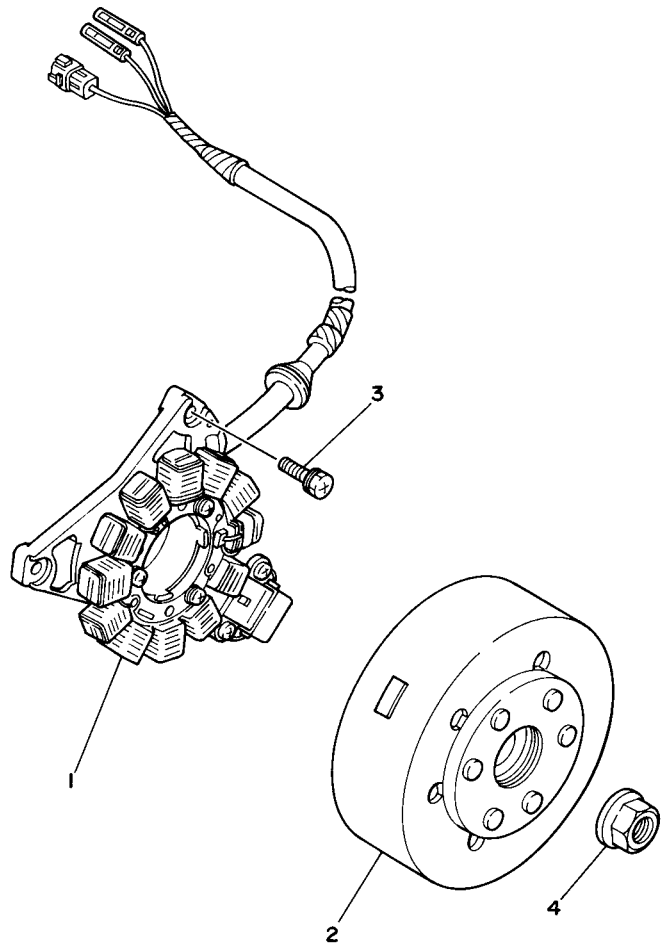

3GGH100-5340

REF. NO.	PART NO.	DESCRIPTION	U49	CAN	FRA	OCE	REMARKS
1	3GG-85510-01	STATOR ASSY	1	1	1	1	
2	3GG-85550-00	ROTOR ASSY	1	1	1	1	
3	90159-06076	SCREW, WITH WASHER	3	3	3	3	
4	90179-12248	NUT	1	1	1	1	

FIG. 35 HEADLIGHT

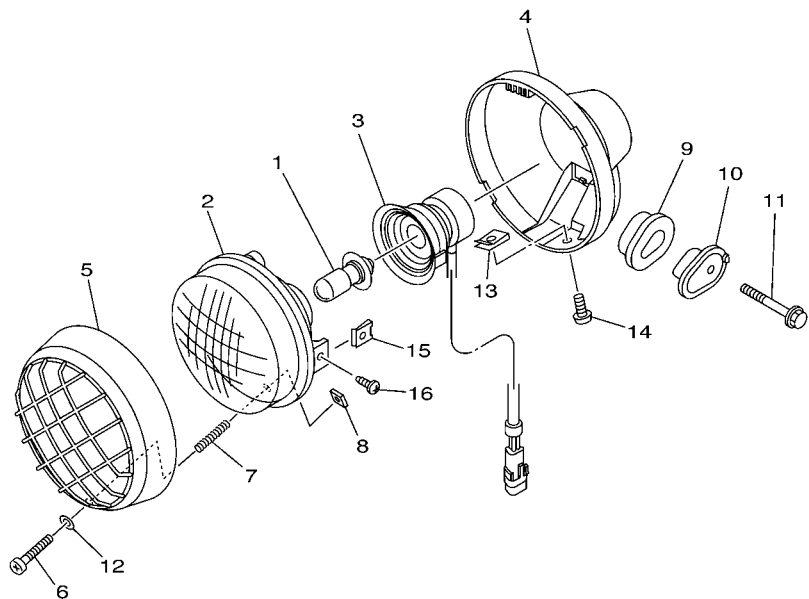

REF. NO.	PART NO.	DESCRIPTION	U49	CAN	FRA	OCE	REMARKS
1	4KB-84314-01	BULB (12V-30/30W)	2	2	2	2	
2	5KM-84320-00	LENS ASSY	2	2	2	2	
3	5EH-84340-00	SOCKET CORD ASSY 1	2	2	2	2	
4	2GU-84330-70	BODY ASSY	2	2	2	2	YB
5	4KB-84169-00	GUARD, HEADLIGHT	2	2	2	2	
6	2GU-84331-00	SCREW, RIM ADJUSTING	2	2	2	2	
7	2GU-84332-00	SPRING, SCREW	2	2	2	2	
8	2GU-84334-00	NUT, ADJUSTING	2	2	2	2	
9	2GU-84345-00	DAMPER, HEADLIGHT	4	4	4	4	
10	2GU-84338-00	COLLAR, BODY FITTING	4	4	4	4	
11	95807-08055	BOLT, FLANGE	2	2	2	2	
12	4KB-84344-00	WASHER, PLAIN	2	2	2	2	
13	4KB-84117-00	NUT	2	2	2	2	
14	4KB-84526-00	SCREW	2	2	2	2	
15	5LP-84334-00	NUT, ADJUSTING	2	2	2	2	
16	4KB-84365-00	SCREW	2	2	2	2	

5FKJ100-B350

FIG. 36 TAILLIGHT

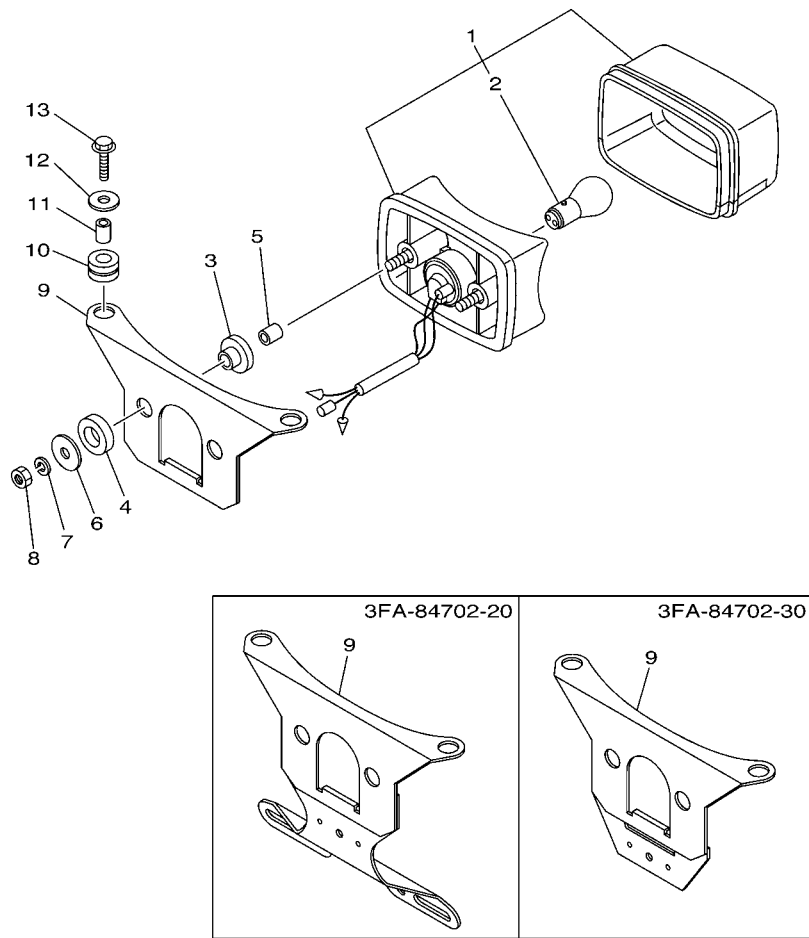

REF. NO.	PART NO.	DESCRIPTION	U49	CAN	FRA	OCE	REMARKS
1	3FA-84710-00	TAILLIGHT UNIT ASSY	1	1	1	1	
2	1A2-84714-41	.BULB (12V-21/5W)	1	1	1	1	
3	90480-14088	GROMMET	2	2	2	2	
4	90202-14077	WASHER, PLATE	2	2	2	2	
5	90387-06595	COLLAR	2	2	2	2	
6	90201-06074	WASHER, PLATE	2	2	2	2	
7	92907-06100	WASHER, SPRING	2	2	2	2	
8	95307-06600	NUT	2	2	2	2	
9	3FA-84702-10	BRACKET, TAILLIGHT	1			1	
	3FA-84702-20	BRACKET, TAILLIGHT		1			
	3FA-84702-30	BRACKET, TAILLIGHT			1		
10	90480-14555	GROMMET	2	2	2	2	
11	90387-065L7	COLLAR	2	2	2	2	
12	90201-06071	WASHER, PLATE	2	2	2	2	
13	95807-06025	BOLT, FLANGE	2	2	2	2	

5FKE100-2360

FIG. 37 HANDLE SWITCH & LEVER

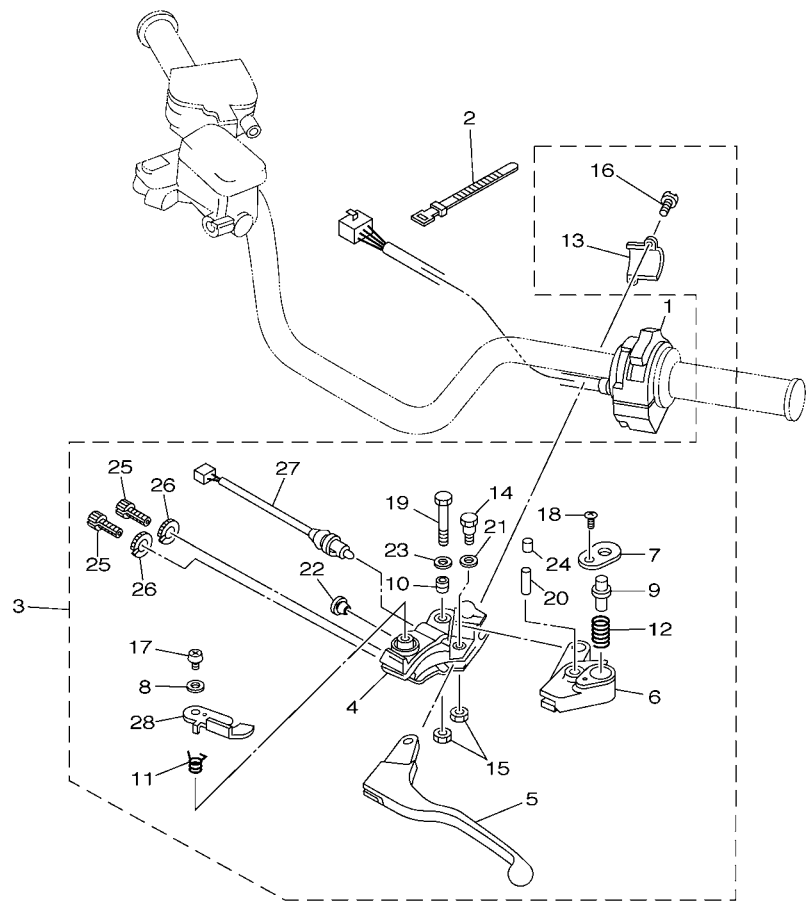

5FKP100-C370

REF. NO.	PART NO.	DESCRIPTION	U49	CAN	FRA	OCE	REMARKS
1	5FK-83975-00	SWITCH, HANDLE 2	1	1	1	1	
2	437-83936-01	BAND, SWITCH CORD	2	2	2	2	
3	3GG-82910-20	LEVER HOLDER ASSY (LEFT)	1	1	1	1	
4	5LP-82911-10	.HOLDER, LEVER 1	1	1	1	1	
5	5LP-83912-00	.LEVER 1	1	1	1	1	
6	5LP-83922-10	.LEVER 2	1	1	1	1	
7	1UY-83935-10	.COVER	1	1	1	1	
8	5LP-83909-10	.WASHER, SPECIAL	1	1	1	1	
9	1UY-83967-10	.PIN, LOCK 1	1	1	1	1	
10	1UY-83913-00	.COLLAR, LEVER 1	1	1	1	1	
11	1UY-83966-00	.SPRING, RETURN	1	1	1	1	
12	1UY-83962-00	.SPRING	1	1	1	1	
13	5LP-82913-10	.HOLDER, LEVER LOWER 1	1	1	1	1	
14	2H7-83945-00	.BOLT, LEVER	1	1	1	1	
15	5LP-84126-10	.NUT, LENS FITTING	2	2	2	2	
16	5LP-83991-10	.SCREW, LEVER 1	2	2	2	2	
17	5LP-83925-10	.SCREW, LEVER FITTING	1	1	1	1	
18	5LP-8396X-10	.SCREW, LEVER FITTING	1	1	1	1	
19	5LP-83945-10	.BOLT, LEVER	1	1	1	1	
20	91690-40022	.PIN, SPRING	1	1	1	1	
21	5LP-8398X-10	.WASHER, PLAIN	1	1	1	1	
22	90338-12192	.PLUG	1	1	1	1	
23	5LP-84127-10	.WASHER, SPECIAL	1	1	1	1	
24	1UY-83956-00	.CAP 1	1	1	1	1	
25	90123-08046	.BOLT	2	2	2	2	
26	90179-08148	.NUT	2	2	2	2	
27	4KB-82917-00	.SWITCH	1	1	1	1	

FIG. 37 HANDLE SWITCH & LEVER

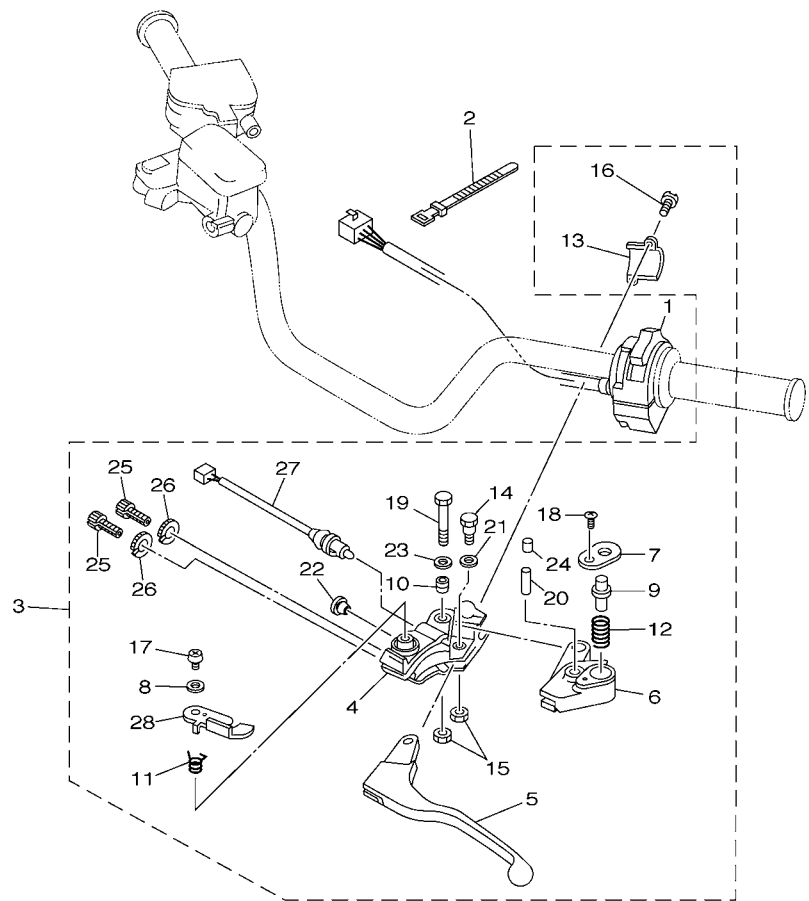

5FKP100-C370

REF. NO.	PART NO.	DESCRIPTION	U49	CAN	FRA	OCE	REMARKS
28	4KB-W8393-00	.LOCK, LEVER ASSY	1	1	1	1	

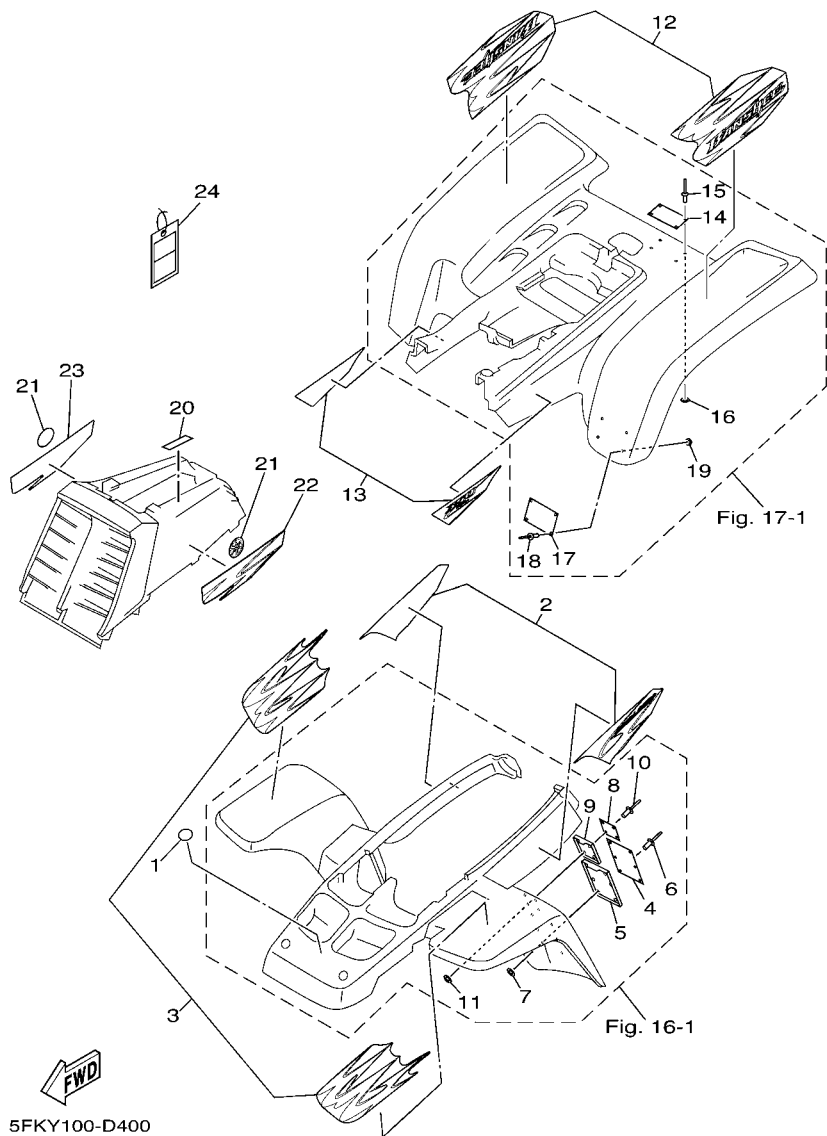

FIG. 40 EMBLEM & LABEL 1

REF. NO.	PART NO.	DESCRIPTION	U49	CAN	FRA	OCE	REMARKS
1	5KM-2175B-00	TUNING FORK MARK	1				
2	5FK-21570-60	GRAPHIC SET, FRONT FENDER	1				
3	5FK-2157A-00	GRAPHIC SET, FRONT FENDER	1				
4	5FE-21568-01	LABEL, WARNING	1				ENGLISH
5	4EM-21581-40	STAY, PLATE FITTING 1	1				
6	90267-32198	RIVET, BLIND	6				
7	90201-03313	WASHER, PLATE	6				
8	5FE-21697-01	LABEL, CAUTION 2	1				ENGLISH
9	3JM-21591-40	STAY, PLATE FITTING 2	1				
10	90267-32198	RIVET, BLIND	4				
11	90201-03313	WASHER, PLATE	4				
12	5FK-2165A-60	GRAPHIC SET, REAR FENDER	1				
13	5FK-2167A-30	GRAPHIC SET	1				
14	5FE-2151H-01	LABEL 5	1				ENGLISH
15	90267-32004	RIVET, BLIND	4				
16	90201-03313	WASHER, PLATE	4				
17	5FK-21696-01	LABEL, CAUTION	1				
18	90267-32004	RIVET, BLIND	4				
19	90201-03313	WASHER, PLATE	4				
20	3XJ-2415E-A0	LABEL, CAUTION	1				ENGLISH
21	5FK-2175C-00	TUNING FORK MARK	2				
22	5FK-2173E-70	GRAPHIC 1	1				
23	5FK-2173F-70	GRAPHIC 2	1				
24	5LP-2819R-00	TAG, WARNING	1				

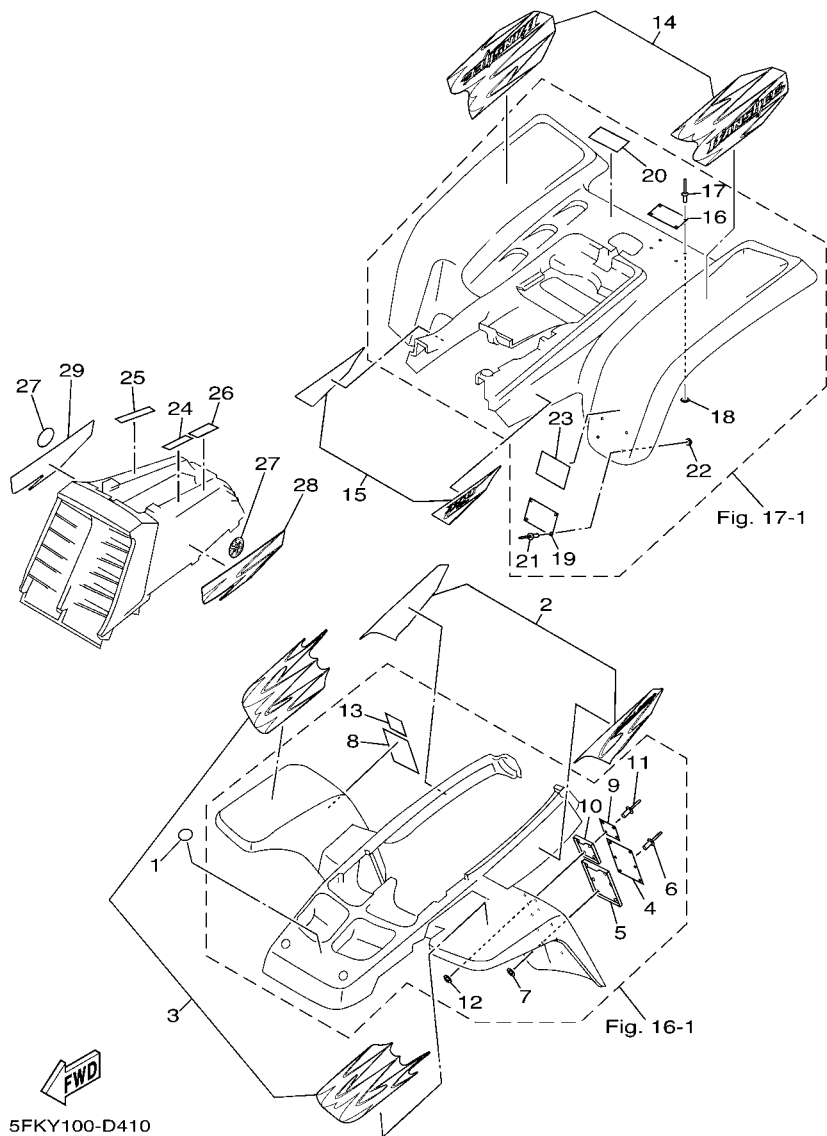

FIG. 41 EMBLEM & LABEL 2

REF. NO.	PART NO.	DESCRIPTION	U49	CAN	FRA	OCE	REMARKS
1	5KM-2175B-00	TUNING FORK MARK		1			
2	5FK-21570-60	GRAPHIC SET, FRONT FENDER		1			
3	5FK-2157A-00	GRAPHIC SET, FRONT FENDER		1			
4	5FE-21568-01	LABEL, WARNING		1			ENGLISH
5	4EM-21581-40	STAY, PLATE FITTING 1		1			
6	90267-32198	RIVET, BLIND		6			
7	90201-03313	WASHER, PLATE		6			
8	4WU-21568-10	LABEL, WARNING		1			FRENCH
9	5FE-21697-01	LABEL, CAUTION 2		1			ENGLISH
10	3JM-21591-40	STAY, PLATE FITTING 2		1			
11	90267-32198	RIVET, BLIND		4			
12	90201-03313	WASHER, PLATE		4			
13	3JM-21697-10	LABEL, CAUTION 2		1			FRENCH
14	5FK-2165A-60	GRAPHIC SET, REAR FENDER		1			
15	5FK-2167A-30	GRAPHIC SET		1			
16	5FE-2151H-01	LABEL 5		1			ENGLISH
17	90267-32004	RIVET, BLIND		4			
18	90201-03313	WASHER, PLATE		4			
19	4WU-2151H-10	LABEL 5		1			FRENCH
20	5FK-21696-01	LABEL, CAUTION		1			
21	90267-32004	RIVET, BLIND		4			
22	90201-03313	WASHER, PLATE		4			
23	5FK-21696-B0	LABEL, CAUTION		1			
24	3XJ-2415E-A0	LABEL, CAUTION		1			ENGLISH
25	3XJ-2415E-B0	LABEL, CAUTION		1			FRENCH
26	4SH-2416E-00	LABEL, CAUTION CANADA		1			ENGLISH
27	5FK-2175C-00	TUNING FORK MARK		2			

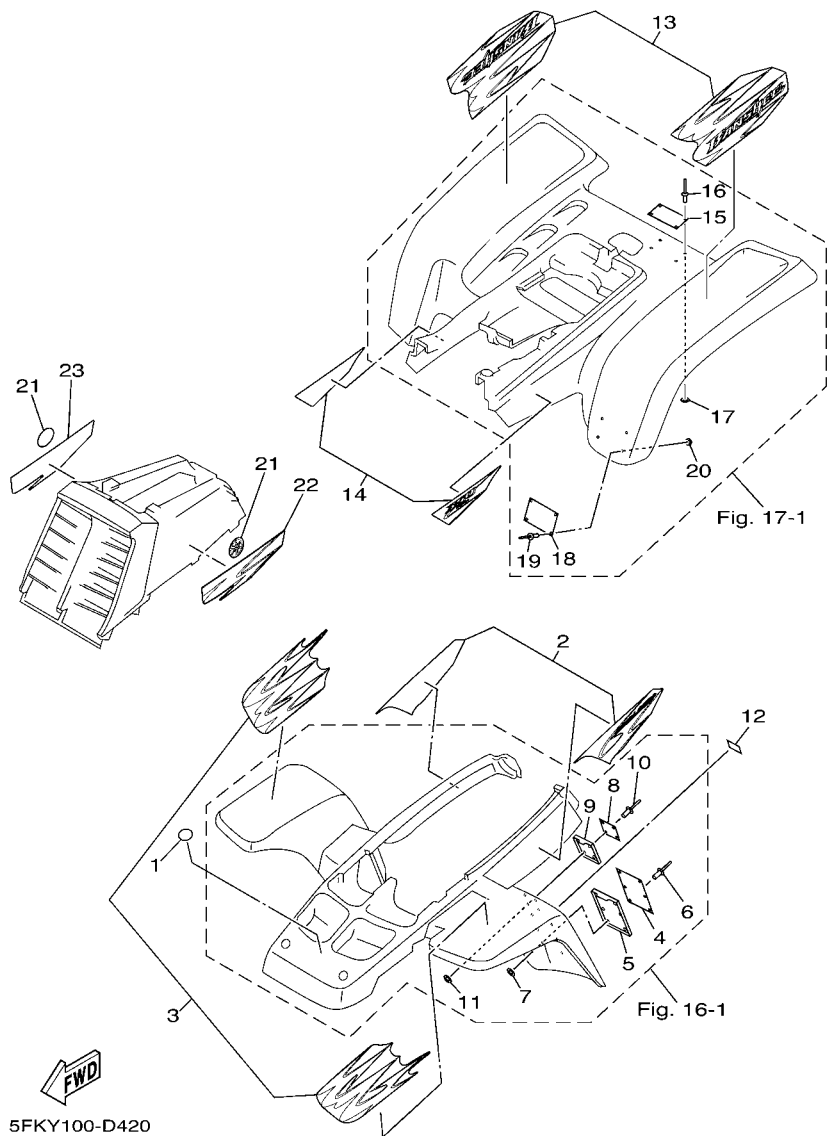

FIG. 42 EMBLEM & LABEL 3

REF. NO.	PART NO.	DESCRIPTION	U49	CAN	FRA	OCE	REMARKS
1	5KM-2175B-00	TUNING FORK MARK			1		
2	5FK-21570-60	GRAPHIC SET, FRONT FENDER			1		
3	5FK-2157A-00	GRAPHIC SET, FRONT FENDER			1		
4	5FK-21568-00	LABEL, WARNING			1		
5	4EM-21581-40	STAY, PLATE FITTING 1			1		
6	90267-32198	RIVET, BLIND			6		
7	90201-03313	WASHER, PLATE			6		
8	5FK-21697-00	LABEL, CAUTION 2			1		
9	3JM-21591-40	STAY, PLATE FITTING 2			1		
10	90267-32198	RIVET, BLIND			4		
11	90201-03313	WASHER, PLATE			4		
12	4GB-2155A-00	MARK, EC			1		
13	5FK-2165A-60	GRAPHIC SET, REAR FENDER			1		
14	5FK-2167A-30	GRAPHIC SET			1		
15	5FK-2151H-00	LABEL 5			1		
16	90267-32004	RIVET, BLIND			4		
17	90201-03313	WASHER, PLATE			4		
18	5FK-21696-M0	LABEL, CAUTION			1		
19	90267-32004	RIVET, BLIND			4		
20	90201-03313	WASHER, PLATE			4		
21	5FK-2175C-00	TUNING FORK MARK			2		
22	5FK-2173E-70	GRAPHIC 1			1		
23	5FK-2173F-70	GRAPHIC 2			1		

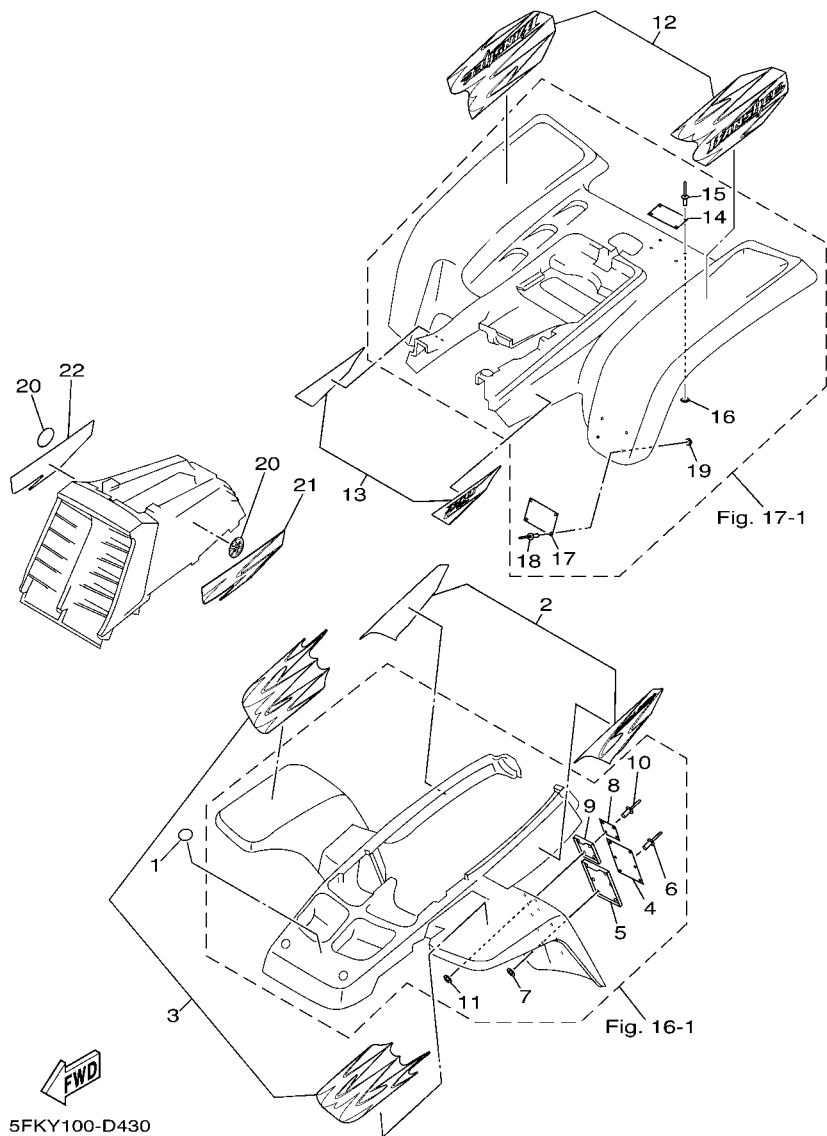

FIG. 43 EMBLEM & LABEL 4

REF. NO.	PART NO.	DESCRIPTION	U49	CAN	FRA	OCE	REMARKS
1	5KM-2175B-00	TUNING FORK MARK				1	
2	5FK-21570-60	GRAPHIC SET, FRONT FENDER				1	
3	5FK-2157A-00	GRAPHIC SET, FRONT FENDER				1	
4	5FE-21568-11	LABEL, WARNING				1	ENGLISH
5	4EM-21581-40	STAY, PLATE FITTING 1				1	
6	90267-32198	RIVET, BLIND				6	
7	90201-03313	WASHER, PLATE				6	
8	5FE-21697-01	LABEL, CAUTION 2				1	ENGLISH
9	3JM-21591-40	STAY, PLATE FITTING 2				1	
10	90267-32198	RIVET, BLIND				4	
11	90201-03313	WASHER, PLATE				4	
12	5FK-2165A-60	GRAPHIC SET, REAR FENDER				1	
13	5FK-2167A-30	GRAPHIC SET				1	
14	5FE-2151H-01	LABEL 5				1	ENGLISH
15	90267-32004	RIVET, BLIND				4	
16	90201-03313	WASHER, PLATE				4	
17	5FK-21696-01	LABEL, CAUTION				1	
18	90267-32004	RIVET, BLIND				4	
19	90201-03313	WASHER, PLATE				4	
20	5FK-2175C-00	TUNING FORK MARK				2	
21	5FK-2173E-70	GRAPHIC 1				1	
22	5FK-2173F-70	GRAPHIC 2				1	

NUMERICAL INDEX

PART NO.	GRID NO.	PART NO.	GRID NO.	PART NO.	GRID NO.	PART NO.	GRID NO.	PART NO.	GRID NO.	PART NO.	GRID NO.
2GU-11111-00	B - 2	137-14143-44	B - 8	2GU-15189-00	B - 13	29L-17421-00	C - 3	4EM-21581-40	E - 14	2GU-21871-00	C - 11
2GU-11181-00	B - 2	137-14143-48	B - 8	2GU-15316-00	B - 11	278-17424-01	B - 3		E - 15	10V-21875-00	C - 11
2GU-11311-00	B - 2	2GU-14146-00	B - 9	31K-15317-00	B - 13		C - 4	2GU-21587-00	C - 9	3GG-22110-00-P0	C - 12
2GU-11321-00	B - 2	2H0-14146-00	B - 8	2GU-15326-00	B - 11	278-17425-00	C - 3	2GU-21588-00	C - 9	2K6-22128-01	C - 12
3GG-11351-01	B - 2	500-14146-00	B - 9	48H-15327-00	B - 13	4L0-17471-00	C - 3	3JM-21591-40	E - 11	23X-22129-00	C - 12
47X-11355-00	B - 2	558-14147-00	B - 9	2GU-15328-00	B - 11	2GU-18101-00	C - 6		E - 12	2GU-22141-00	C - 12
29L-11400-30	B - 3	137-14153-00	B - 8	2GU-15337-00	B - 13	2GU-18110-01	C - 6		E - 14	2GU-22151-10	C - 12
29L-11409-30	B - 3	2GU-14153-00	B - 8	2GU-15338-00	B - 13	132-18113-01	C - 6		E - 15	2GU-22153-00	C - 13
29L-11412-00	B - 3	2GU-14161-00	B - 9	4L0-15362-00	B - 13	4L0-18140-00	C - 5	3GG-21621-00	C - 10	2GU-22155-00	C - 13
29L-11442-10	B - 3	2GU-14171-00	B - 9	120-15371-00	B - 11	4L0-18185-00	C - 5	5FK-2165A-60	E - 11	2HH-22178-00	C - 7
2GU-11610-01	B - 3	239-14172-16	B - 8	5FK-15377-00	B - 13	2GU-18511-00	C - 5		E - 12	1UY-2217A-00	C - 12
2GU-11610-11	B - 3	304-14184-00	B - 8	2GU-15379-00	B - 13	2GU-18512-00	C - 5		E - 14	3GG-2217F-00	C - 12
2GU-11610-21	B - 3	4L0-14185-00	B - 8	2GU-15411-00	B - 13	4L0-18531-01	C - 5		E - 15	2GU-22184-00	C - 12
2GU-11631-00-94	B - 3	537-14186-00	B - 8	2GU-15416-00	B - 13	29L-18535-00	C - 5	5FK-2167A-30	E - 11	5X4-22199-00	C - 12
4L0-11633-00	B - 3	1UA-14190-28	B - 8	2GU-15421-00	B - 13	2GU-18540-00	C - 5		E - 12	3GG-2219X-00	C - 13
2GU-11635-00	B - 3	12R-14191-00	B - 8	4L0-15431-01	B - 13	3R4-18561-00	C - 5		E - 14	3GG-22201-42	C - 14
2GU-11636-00	B - 3	2GU-14196-00	B - 8	3GG-15461-02	B - 13	4L0-18562-00	C - 5		E - 15	3GG-22210-42-33	C - 14
29L-11651-00	B - 3	4L0-14197-00	B - 8	278-15492-01	B - 11	3GG-21110-21-P0	C - 7	3GG-21691-00	C - 10	3GG-22210-52-33	C - 14
4L0-12422-00	B - 4	2GU-14243-00	B - 9	2GU-15620-01	B - 14	2GU-21314-00	C - 8	5FK-21696-01	E - 11	3GG-22210-72-33	C - 14
3GG-12428-01	B - 4	2GU-14411-00	B - 6	4L0-15641-00	B - 14	2GU-21315-00	C - 7		E - 12	38W-22212-10-33	C - 14
3XV-12435-00	B - 5	2GU-14412-00	B - 6	4L0-15651-00	B - 14	2GU-21316-00	C - 7		E - 15	22W-22214-01	C - 14
4L0-12436-00	B - 4	2GU-14421-01	B - 6	4L0-15660-01	B - 14	2GU-21317-00	C - 7	5FK-21696-B0	E - 12	1RK-22215-00	C - 14
4L0-12450-01	B - 4	2GU-14437-00	B - 6	4L0-15666-00	B - 14	2GU-21318-00	C - 7	5FK-21696-M0	E - 14	38W-22223-00	C - 14
4L0-12459-00	B - 4	2GU-14451-00	B - 6	248-15668-00	B - 14	5FK-2144G-00	E - 9	5FK-21697-00	E - 14	4AA-22259-40	C - 14
2GU-12460-01	B - 5	12R-14452-00	B - 6	4L0-16111-00	B - 15	4L0-21485-00	C - 8	5FE-21697-01	E - 11	4AA-22259-70	C - 14
22W-12462-00	B - 5	29L-14452-00	B - 6	31K-16150-10	B - 15	2GU-21513-00	C - 9		E - 12	4AA-22259-80	C - 14
29L-12469-00	B - 5	29L-14453-01	B - 6	360-16154-00	B - 15	2GU-21514-00	C - 9		E - 15	CA4-22464-00	C - 14
4L0-12479-00	B - 5	59V-14457-00	B - 6	278-16181-01	B - 15	5FK-2151H-00	E - 14	3JM-21697-10	E - 12	59V-2331R-00	D - 4
29L-12481-00	B - 5	5FK-14458-00	B - 6	498-16325-00	B - 15	5FE-2151H-01	E - 11	2GU-21711-B0	C - 11	3GG-23350-10-33	D - 4
2GU-12482-00	B - 5	29L-14465-00	B - 6	5Y1-16331-01	B - 15		E - 12	2GU-2171L-00	C - 11	3GG-23350-20-33	D - 4
2GU-12484-00	B - 5	2GU-14468-00	B - 6	29L-16351-00	B - 15		E - 15	2GU-21721-B0	C - 11	5FK-23391-D0	C - 11
2GU-12485-00	B - 5	2GU-14610-00	B - 10	29L-16356-00	B - 15	4WU-2151H-10	E - 12	5FK-2173E-70	E - 11	3GD-23501-00	D - 7
11H-12516-00	B - 5	2GU-14613-10	B - 10	29L-16357-00	B - 15	4GB-2155A-00	E - 14		E - 13	3GD-23502-00	D - 7
31K-13565-01	B - 6	2GU-14615-00	B - 10	278-16367-00	B - 15	5FK-21568-00	E - 14		E - 14	1UY-23517-00	D - 3
2GU-13610-01	B - 6	2GU-14620-00	B - 10	1A0-16371-00	B - 15	5FE-21568-01	E - 11		E - 15	3GG-23540-00-P0	D - 3
2GU-13613-00	B - 6	2GU-14635-00	B - 10	29L-16380-00	B - 15		E - 12	5FK-2173F-70	E - 11	3GG-23550-00-P0	D - 3
2GU-13616-00	B - 6	2GU-14645-00	B - 10	2GU-17121-00	C - 3	4WU-21568-10	E - 12		E - 13	2GU-23570-00-P0	D - 3
3GG-13621-00	B - 6	1W2-14714-00	B - 10	2GU-17131-00	C - 3	5FE-21568-11	E - 15		E - 14	2GU-23580-00-P0	D - 3
2GU-14101-01	B - 8	2GU-14718-00	B - 10	2GU-17151-00	C - 3	5FK-21570-60	E - 11		E - 15	1UY-23812-00	C - 15
2GU-14102-01	B - 8	2GU-14728-00	B - 10	2GU-17161-00	C - 3		E - 12	2GU-21747-00	C - 11	3GG-23813-01	C - 15
10W-14104-00	B - 8	2GU-14752-00	B - 10	2GU-17211-00	C - 3		E - 14	5KM-2175B-00	E - 11	8K1-23814-00	C - 15
2GU-14112-20	B - 8	2GU-14753-01	B - 10	2GU-17221-00	C - 3		E - 15		E - 12	2GU-23831-01	C - 15
2GU-14113-20	B - 8	2GU-14765-01	B - 10	2GU-17231-00	C - 3	5FK-2157A-00	E - 11		E - 14	1UY-23841-01	C - 15
2GU-14131-00	B - 8	4BD-14766-00	B - 10	2GU-17241-00	C - 3		E - 12		E - 15	1UY-23845-01	C - 15
4L0-14141-38	B - 8	2GU-14771-00	B - 10	2GU-17251-00	C - 3		E - 14	5FK-2175C-00	E - 11	2GU-23868-00	C - 15
260-14142-25	B - 8	2GU-1490J-00	B - 8	2GU-17261-01	C - 3		E - 15		E - 12	2GU-23872-00	C - 7
137-14143-38	B - 8	2GU-14952-00	B - 9	2GU-17411-00	C - 3	4EM-21581-40	E - 11		E - 14	1UY-23894-01	C - 15
137-14143-40	B - 8	2GU-15100-01	B - 11	164-17417-00-10	B - 14		E - 12		E - 15	2GU-24110-00	D - 5

NUMERICAL INDEX

PART NO.	GRID NO.	PART NO.	GRID NO.	PART NO.	GRID NO.	PART NO.	GRID NO.	PART NO.	GRID NO.	PART NO.	GRID NO.
3XJ-2415E-A0	E - 11	2GU-25866-00	D - 14	5LP-2819R-00	E - 11	5LP-84127-10	E - 7	90105-08440	D - 11	90171-10046	C - 15
	E - 12	5LP-25867-00	D - 14	5GT-2836B-10	D - 12	4KB-84169-00	E - 5	90105-08538	D - 8		D - 7
3XJ-2415E-B0	E - 12	2GU-25871-00	D - 14	1UY-28415-00	E - 3	4KB-84314-01	E - 5	90105-10034	D - 3	90171-14020	D - 7
4SH-2416E-00	E - 12	2GU-25872-02	D - 14	3GG-2845N-00-P1	E - 3	5KM-84320-00	E - 5	90105-10328	C - 7	90171-14037	D - 9
48H-24311-00	B - 9	3GG-25873-11	D - 14	3GG-2845N-10-P1	E - 3	2GU-84330-70	E - 5	90105-10388	D - 4	90179-08148	E - 7
4X7-24311-00	B - 9	3GG-25874-02	E - 2	3GG-2845R-00	E - 3	2GU-84331-00	E - 5	90105-10444	C - 7	90179-08299	B - 2
2GU-24500-02	D - 5	2GU-25882-00	D - 14	3GG-2845R-10	E - 3	2GU-84332-00	E - 5	90105-10651	D - 3	90179-10247	D - 10
4X8-24512-00	D - 5	1A1-25894-01	E - 2	898-81910-12	E - 9	2GU-84334-00	E - 5	90109-063F7	C - 5	90179-12248	E - 4
3AC-24523-00	D - 5	2GU-25895-00	E - 2	82F-81910-A0	E - 9	5LP-84334-00	E - 5	90109-06557	E - 9	90179-12588	D - 10
3AJ-24534-01	D - 5	5MV-2589F-00	D - 14	2GU-82310-51	E - 9	2GU-84338-00	E - 5	90109-081F0	D - 11	90179-18020	C - 4
5KM-24610-00	D - 5	4NK-2589H-00	D - 14	1M1-82370-30	E - 9	5EH-84340-00	E - 5	90109-082E9	C - 15	90183-05024	C - 11
5FK-2470F-E0	D - 6	1UY-25917-51	D - 11	5FK-82510-00	E - 9	4KB-84344-00	E - 5	90109-102A6	C - 12	90185-10060	D - 3
5FK-24710-E0	D - 6	1UY-25924-51	D - 11	5FK-82530-00	E - 9	2GU-84345-00	E - 5		C - 14	90185-10115	C - 15
22W-24741-00	D - 6	3GD-25933-00	D - 8	278-82540-01	E - 9	4KB-84365-00	E - 5	90109-10654	C - 13	90185-10120	C - 12
4K0-24774-01	D - 6	1UY-25972-51	D - 11	3GG-82567-00	D - 12	4KB-84526-00	E - 5	90109-10704	C - 14		C - 14
4K0-24775-00	D - 6	1UY-25977-51	D - 11	3HN-82569-00	E - 9	3FA-84702-10	E - 6	90109-10752	C - 12	90185-16127	C - 12
3GD-24776-00	D - 6	5LP-26111-30	D - 12	3HN-82579-00	E - 9	3FA-84702-20	E - 6	90114-10007	D - 7	90201-03313	E - 11
3GD-25111-01	D - 7	2GU-26124-01	D - 12	5FK-82590-00	E - 9	3FA-84702-30	E - 6	90114-10009	D - 9		E - 12
1UY-25117-00	D - 7	1NV-26129-00	D - 12	3GG-8259E-00	B - 9	3FA-84710-00	E - 6	90116-08064	B - 2		E - 14
3GD-25127-00	D - 7	5LP-26241-00	D - 12	3GG-82910-20	E - 7	1A2-84714-41	E - 6		B - 11		E - 15
3GD-2514A-10	D - 8	3GG-26250-00	D - 12	5LP-82911-10	E - 7	2EK-85111-00	E - 10	90116-08232	B - 11	90201-047A2	C - 11
3GD-2515A-10	D - 8	1UY-26259-00	D - 14	4V4-82913-00	D - 12	3Y6-85130-02	E - 10	90116-08318	B - 2	90201-06071	E - 6
2XK-25180-10-HM	D - 7	2GU-26259-00	D - 12	5LP-82913-10	E - 7	449-85131-02	E - 10	90116-08388	B - 2	90201-06074	E - 6
3GG-25311-01-P1	D - 9	2GU-2625G-01	D - 12	4KB-82917-00	E - 7	3GG-85510-01	E - 4	90116-08394	B - 2	90201-060A3	B - 5
38W-25381-02	D - 9	2GU-2625H-00	D - 12	5LP-83909-10	E - 7	3GG-85540-10	E - 9	90116-08507	D - 9	90201-060L5	D - 5
5LP-25383-10	D - 9	2GU-2625J-00	D - 12	5LP-83912-00	E - 7	3GG-85550-00	E - 4	90119-06056	C - 10	90201-08083	E - 2
2XJ-25386-00	D - 9	2GU-26260-01	D - 12	1UY-83913-00	E - 7	3GG-85590-00	E - 9	90119-06096	B - 7	90201-08326	B - 10
2XJ-25388-00	D - 9	2GU-2628F-00	D - 12	5LP-83922-00	D - 14	5LP-W0041-00	D - 14	90123-08046	E - 7	90201-086P8	C - 7
2XK-25390-01-HM	D - 9	2GU-2628G-00	D - 12	5LP-83922-10	E - 7	5FK-W0042-50	E - 2	90149-06011	D - 5	90201-08784	B - 4
2XJ-25412-00	D - 9	2GU-2629K-00	C - 15	5LP-83925-10	E - 7	5LP-W0045-00	D - 8	90149-06306	C - 9	90201-100E9	C - 13
2XJ-25441-21	D - 9	2GU-26314-00	D - 12	1UY-83935-10	E - 7	1UY-W0046-00	D - 11		C - 10		C - 14
2GU-25712-00	D - 11	5FK-26335-00	D - 12	437-83936-01	D - 12	3GD-W0047-00	D - 8	90149-08143	B - 15	90201-10118	D - 14
5LP-2580T-00	D - 8	2GU-2633K-00	B - 9		E - 7	1UY-W0047-50	D - 11	90149-08256	C - 6		E - 2
5LP-2580U-00	D - 8	1UY-26341-02	D - 13		E - 9	1UY-W0048-50	D - 8	90149-08268	D - 8	90201-10430	C - 12
1UY-2580W-00	D - 11	1UY-2637A-01	D - 13	437-83936-11	E - 9		D - 11	90150-06037	C - 10		C - 14
3GD-25827-00	D - 8	2GU-26398-00	D - 12	2H7-83945-00	E - 7	3GD-W0057-00	D - 8	90152-06010	B - 14		D - 3
3GD-25828-00	D - 8	371-27114-00	D - 6	5LP-83945-10	E - 7	1UY-W0057-50	D - 11	90154-05013	C - 11	90201-106F2	D - 10
29L-2582A-50	E - 2	4N0-27114-00	C - 8	1UY-83956-00	E - 7	2GU-W2151-F0	C - 9	90159-06016	B - 15	90201-10774	C - 15
3GD-2582T-10	D - 8		C - 12	1UY-83962-00	E - 7	2GU-W215B-F0	C - 9	90159-06056	E - 2	90201-120E6	C - 13
5FK-2582W-00	D - 11	3GG-27211-00	D - 15	1UY-83966-00	E - 7	2GU-W215C-F0	C - 9	90159-06076	E - 4		C - 14
5MV-25833-00	D - 14	4SS-27218-00	E - 2	1UY-83967-10	E - 7	2GU-W215E-F0	C - 9	90159-06082	C - 11	90201-126A7	D - 10
5LP-2583T-01	D - 14	2YK-27222-00	E - 2	5LP-8396X-10	E - 7	2GU-W2161-E0	C - 10	90159-06093	D - 12	90201-14226	D - 9
5FK-2583V-00	E - 2	3GG-27241-01	D - 15	5FK-83975-00	E - 7	2GU-W216B-E0	C - 10	90170-08029	C - 6	90201-14586	D - 7
5LP-25852-01	D - 14	3GG-27421-01	D - 15	5LP-83980-00	D - 14	2GU-W216C-E0	C - 10	90170-08258	D - 9	90201-15797	D - 15
2KF-25852-50	E - 2	3GD-27445-00	D - 15	5LP-8398X-10	E - 7	4KB-W8393-00	E - 8	90170-10186	C - 15	90201-160F6	C - 12
4L0-25854-00	D - 14	3GG-27446-00	D - 15	5LP-83991-10	E - 7	90101-08777	D - 9	90170-16425	B - 15	90201-17327	B - 15
360-25854-01	E - 2	2GU-28100-10	C - 8	4KB-84117-00	E - 5	90101-10685	D - 9	90170-20320	B - 15	90201-20266	C - 3
2GU-25855-00	E - 2	1NV-2811A-01	C - 8	5LP-84126-10	E - 7	90101-12694	D - 10	90170-33376	D - 11	90201-20276	C - 3

NUMERICAL INDEX

PART NO.	GRID NO.	PART NO.	GRID NO.	PART NO.	GRID NO.	PART NO.	GRID NO.	PART NO.	GRID NO.	PART NO.	GRID NO.
90201-244A9	C - 12	90387-126H8	C - 14	90480-14088	E - 6	92907-10100	C - 7	93399-99916	C - 14	95807-08040	C - 12
90201-25490	C - 4	90387-127G8	C - 14	90480-14555	E - 6	92907-10200	D - 7	93430-08007	C - 5	95807-08055	E - 5
90201-256E6	C - 3	90387-150R1	D - 7	90480-15470	B - 5		D - 9	93430-12008	D - 15	95817-08014	B - 10
90202-05193	D - 5	90387-176R6	C - 15	90480-18171	B - 7	92907-10600	C - 8	93430-20454	D - 6		E - 3
90202-14077	E - 6	90387-257N4	C - 4	90480-18290	D - 5	92990-04100	B - 8	93440-19083	B - 5	95817-08025	C - 7
90206-06090	B - 10	90401-10159	D - 14	90480-18411	D - 15	92990-10600	C - 7	93440-25084	C - 3	95817-10025	D - 15
90208-16019	B - 15		E - 2	90480-48399	C - 11	93102-12106	C - 6	93440-30113	C - 14	95827-06010	B - 2
90209-21105	C - 3	90413-05014	B - 11	90501-12081	B - 14	93102-17004	B - 15	93440-34025	C - 5		C - 9
90209-22292	B - 3	90413-08009	B - 9	90501-23138	B - 15	93102-20484	B - 14	93440-52009	C - 3	95827-08016	D - 15
90214-15020	B - 14	90430-06166	B - 2	90506-18398	B - 10	93102-22216	D - 7	93450-17129	B - 3		E - 3
90215-08174	C - 6	90430-14043	B - 11	90506-20380	D - 15	93102-25081	C - 7	93507-32031	B - 14	95827-08020	C - 13
90215-20223	B - 15	90445-081F1	B - 11	90507-20030	B - 10	93102-25099	C - 7	93515-32029	B - 15	95827-08035	C - 15
90215-21121	C - 4	90445-084J0	C - 11	90508-16599	C - 2	93102-35369	C - 4	93603-22028	B - 4	95917-08640	B - 2
90240-08013	E - 2	90445-084J1	D - 5	90508-20454	D - 6	93102-42260	D - 9	93604-12037	C - 5	97007-06010	C - 2
90267-32004	E - 11	90445-09012	B - 9	90508-29728	C - 5	93102-43341	D - 9	93700-06004	C - 12	97007-06016	E - 9
	E - 12	90445-090F7	C - 11	90508-30051	B - 14	93103-10147	B - 4		D - 4	97007-06020	E - 9
	E - 14	90445-09109	B - 11	90508-32374	C - 6	93103-25108	B - 3	93834-14050	C - 4	97017-06045	B - 11
	E - 15	90445-09123	B - 11	90560-12171	C - 6	93103-40077	B - 3	93900-00022	D - 7	97017-06060	B - 11
90267-32198	E - 11	90445-13693	D - 5	90560-35263	D - 9	93104-09025	D - 12		D - 9	97017-06090	B - 11
	E - 12	90450-32015	B - 5	91317-06020	B - 5	93104-18077	C - 14	94107-10012	D - 7	97017-08020	C - 6
	E - 14	90450-44046	B - 6	91317-06025	B - 6	93105-26026	D - 7	94110-09011	D - 9	97027-06030	D - 5
	E - 15	90460-37026	B - 10	91401-16012	E - 2	93108-35004	C - 12	94681-87011	D - 9	97027-06045	C - 13
90267-40076	C - 11	90460-49058	B - 9	91401-20020	C - 15	93109-20076	C - 12	94701-00204	B - 2	97027-08016	C - 9
90280-05033	B - 3	90460-68230	B - 6		D - 7	93112-31011	C - 15	94702-00204	B - 2	97027-08025	D - 14
90282-07023	B - 15	90460-99291	B - 6	91401-30025	D - 7	93210-14369	B - 14	95027-08045	C - 7	97027-08030	B - 14
90334-10006	C - 5	90462-08078	E - 9	91401-30030	D - 9	93210-15620	E - 2	95306-05700	D - 12	97027-08060	C - 15
90336-28053	C - 15	90462-16130	B - 11	91690-40022	E - 7	93210-17239	B - 5	95307-05600	E - 10	97027-10020	C - 7
90336-42049	B - 14	90465-06094	B - 11	92017-08016	D - 15	93210-19123	B - 13	95307-06600	E - 6	97027-10040	C - 8
90338-06190	B - 12	90465-16239	C - 2	92017-08025	E - 2	93210-29147	E - 9	95307-08600	D - 9	97027-10045	C - 8
90338-12192	E - 7	90465-18312	B - 6	92901-04600	E - 2	93210-45742	B - 10	95307-10700	C - 15	97707-50525	B - 6
90338-15189	B - 13	90465-32317	B - 13	92901-05100	B - 9	93300-60804	C - 7	95317-08700	B - 15	98501-05008	B - 9
90340-14132	B - 11	90467-07093	B - 11	92902-04100	E - 2	93305-20508	C - 3	95317-10600	C - 7	98502-04008	B - 8
90381-15088	D - 3	90467-08003	C - 11	92907-03100	B - 6	93306-00406	D - 7	95602-05100	D - 12	98506-05020	D - 12
90383-12022	B - 11	90467-08021	B - 11		B - 9	93306-00438	D - 7	95604-06100	D - 14	98507-03008	B - 6
90383-20032	C - 12	90467-08075	B - 11	92907-03600	B - 9	93306-00705	D - 9	95607-06100	C - 9		D - 5
90383-20033	C - 12		C - 11	92907-05100	D - 12	93306-20227	D - 7		C - 10	98507-03010	B - 9
90387-063G3	B - 5	90467-10008	B - 9		E - 10	93306-20331	C - 7		C - 13	98507-04006	C - 14
90387-06595	E - 6	90467-11106	B - 9	92907-05200	E - 10	93306-30002	B - 4	95607-06200	E - 9	98507-05010	B - 11
90387-065L7	E - 6		D - 5	92907-06100	D - 5	93306-30504	C - 4	95607-08100	C - 13	98507-05014	B - 13
90387-066J1	D - 5	90467-13083	B - 5		E - 6	93306-30548	B - 3	95607-08200	C - 7	98507-05020	D - 12
90387-0714B	B - 5	90467-14057	E - 2		E - 9	93306-30549	B - 3	95707-06500	D - 6	98507-06012	C - 3
90387-07598	D - 5	90467-20085	B - 6	92907-06200	B - 11	93310-316H6	B - 3	95707-08500	B - 11	98507-06016	B - 4
90387-086N4	C - 7	90467-22080	B - 7		C - 10	93310-522L4	B - 3		D - 15	98507-06020	B - 13
90387-090R0	C - 15	90468-05184	B - 6	92907-06600	C - 13	93311-22005	C - 3	95707-10500	D - 7		E - 9
90387-100Y6	D - 3	90468-26091	B - 14		E - 9	93311-42006	C - 3		D - 9	98507-06030	B - 13
90387-101R3	D - 3	90480-01400	D - 5	92907-08200	B - 15	93315-11720	B - 15	95807-06010	D - 8	98507-06040	B - 13
90387-125N8	C - 12	90480-05201	D - 15	92907-08600	C - 13	93315-23612	C - 5	95807-06025	B - 5	98507-06055	B - 13
90387-125N9	C - 12	90480-12299	C - 7		D - 14	93317-22237	C - 12		E - 6	98511-04012	E - 2

NUMERICAL INDEX

PART NO.	GRID NO.	PART NO.	GRID NO.	PART NO.	GRID NO.	PART NO.	GRID NO.	PART NO.	GRID NO.
98511-04016	B - 8								
98707-05012	E - 9								
98707-05016	C - 5								
98707-06014	C - 5								
98902-03006	D - 12								
98907-06010	B - 10								
99001-07600	B - 4								
99009-15400	B - 14								
99009-20400	C - 3								
99510-12016	B - 11								
99530-10114	B - 2								
99530-12016	B - 13								
9Y581-87103	D - 9								